



PALAVRAS CHAVES/KEY WORDS  
AUTORES/AUTHORS  
ARTIFICIAL INTELLIGENCE  
KNOWLEDGE-BASED SYSTEMS  
PLANNING, INTERROGABLE DATA-COLLECTING PLATFORMS

AUTORIZADA POR/AUTHORIZED BY  
*Marco Antonio Haupp*  
2. Diretoria Geral

AUTOR RESPONSÁVEL  
RESPONSIBLE AUTHOR  
*Valter Rodrigues*

DISTRIBUIÇÃO/DISTRIBUTION  
 INTERNA / INTERNAL  
 EXTERNA / EXTERNAL  
 RESTRITA / RESTRICTED

REVISADA POR / REVISED BY

CDU/UDC  
681.3.019

DATA / DATE  
September 1988

PUBLICAÇÃO Nº  
PUBLICATION NO  
INPE-4707-PRE/1389

TÍTULO/TITLE  
TOWARDS A KNOWLEDGE-BASED SYSTEM TO ASSIST  
THE BRAZILIAN DATA-COLLECTING  
SYSTEM OPERATION

AUTORES/AUTHORSHIP  
Valter Rodrigues  
Paulo Ouverá Simoni  
Pedro Paulo B. de Oliveira  
Carlos Alberto de Oliveira  
Carlos Antonio Marques Nogueira

ORIGEM  
ORIGIN  
LAC

PROJETO  
PROJECT  
INTAL

Nº DE PAG.  
NO OF PAGES  
15

ULTIMA PAG.  
LAST PAGE  
09

VERSÃO  
VERSION

Nº DE MAPAS  
NO OF MAPS

RESUMO - NOTAS / ABSTRACT - NOTES

In this paper it is reported a study carried out to show how a knowledge-based approach would lead to a flexible tool to assist the operation task in a satellite-based environmental data collection. Some characteristics of a hypothesized system comprised of a satellite and a network of Interrogable Data Collecting Platforms (IDCPs) are pointed out. It is briefly described the Knowledge-Based Planning Assistant System (KBPAS) and some aspects about how knowledge is organized in the IDCP's domain.

OBSERVAÇÕES/REMARKS  
To be presented in the Fourth Conference on Artificial Intelligence for Space Applications - AISA'88, November 15-16, 1988, Huntsville, Alabama, U.S.A.



• • •

#### RESUMO

*Neste artigo é relatado um estudo efetuado sobre a maneira que uma abordagem baseada em conhecimento conduziria a uma ferramenta para assistir à tarefa de operação da coleta de dados baseada em satélite. Algumas características de um sistema hipotético, compreendendo o satélite e uma rede de Plataformas Interrogáveis de Coleta de Dados (PICDs), são evidenciadas. Resumidamente é descrito um Sistema baseado em conhecimento de auxílio à planejamento, e alguns aspectos sobre como o conhecimento é organizado no domínio das PICDs.*

## SUMMARY

	<u>Page</u>
1 - INTRODUCTION .....	1
2 - USING KNOWLEDGE-BASED TECHNOLOGY .....	3
2.1 - Knowledge use in the IDCPs network operation task .....	3
2.2 - Response time .....	3
2.3 - Explanation capability .....	4
3 - THE KNOWLEDGE-BASED PLANNING ASSISTANT SYSTEM (KBPAS) .....	4
4 - CONCLUDING REMARKS .....	6
REFERENCES .....	6

• •

**TOWARDS A KNOWLEDGE-BASED SYSTEM TO ASSIST THE BRAZILIAN  
DATA-COLLECTING SYSTEM OPERATION**

RODRIGUES, V.; SIMONI, P.O.; OLIVEIRA, P.P.B.;  
OLIVEIRA, C.A.; NOGUEIRA, C.A.M.

Institute for Space Research  
Computing and Applied Mathematics Laboratory  
Artificial Intelligence Group

Caixa Postal 515  
12201 - São José dos Campos - SP  
Brazil

**ABSTRACT**

In this paper it is reported a study carried out to show how a knowledge-based approach would lead to a flexible tool to assist the operation task in a satellite-based environmental data collection. Some characteristics of a hypothesized system comprised of a satellite and a network of Interrogable Data Collecting Platforms (IDCPs) are pointed out. It is briefly described the Knowledge-Based Planning Assistant System (KBPAS) and some aspects about how knowledge is organized in the IDCP's domain.

**1 - INTRODUCTION**

The first phase of the Brazilian Complete Space Mission (MECB) is to be accomplished with the launching of the first Brazilian Data Collecting Satellite (SCD1). The system will offer capabilities for satellite-based environmental data collection.

This system will comprise: a) a network of fixed "Data Collecting Platforms (DCPs)" deployed at the Brazilian territory both on land and in the air, all of them independently transmitting the environmental data. The DCPs will be equipped with only one transmitter for uplinking messages to the satellite; b) the Satellite, which will have the following main characteristics: low circular orbit around Earth with average altitude about 750 km and nominal inclination about 25 degrees with relation to the Earth equatorial plane. It will retransmit to a ground-station the environmental data received from the DCPs, and it will receive the DCP messages on a random access basis; c) the Ground Station and the Processing Center, where data will be received, processed and distributed to users.

The SCD1 will be able to receive message transmitted only by platforms within its visibility area and to retransmit these messages when the satellite will be over the ground station visibility area. In addition, the access to the satellite by some DCPs will also be dependent on the number of platforms under its sight, the satellite-platform relative position, the platform repetition period, the message length, the transmission power and other secondary factors [1].

Considering that due to a design option all DCPs will transmit in the same frequency, the received frequencies by the satellite will be randomly distributed because of the difference in Doppler shifts associated with a random geographic distribution of DCPs on the Brazilian territory. Therefore the main predicted drawback will be the risk of non-acquisition of messages from some DCP, due either to interferences from simultaneous transmission (which may produce the same received frequency), or to the unavailability of a transponder unit, since the Satellite will have only two transponder units [1]. In fact, during the interval when the satellite is retransmitting a specific DCP data all other DCP message transmissions would not be received and consequently their data would be lost; in order to avoid this problem the DCPs will repeat their messages several times during a satellite overpass.

The system ought to operate all the time, attempting to obtain maximum availability and minimum data loss. However, it has been difficult to know "a priori" what will be the "system use factor" defined as the message mean arrival rate at the receiver. Taking into account simulation studies about a similar system, the ARGOS system [2], it can be estimated that the satellite will be able to handle up to 1000 DCPs simultaneously with message duration randomly distributed between 0.36 and 0.925 seconds.

From the preceding observations, it is clear that the system would not be flexible enough to select the most important DCPs at each pass, even though their high message repetition rate may enhance their likelihood of accessing the Satellite.

Considering this problem, it has been carried out a study about a hypothesized system composed of: a) a network of "Interrogable Data Collecting Platforms (IDCPs)". It means that the satellite will have the ability to select, in a particular time, a particular IDCP. The DCPs in this system will be more complex, because they should be equipped with a receiver and a transmitter; b) a satellite with the capability of interrogating an IDCP and also of receiving and retransmitting its data immediately afterwards; c) the processing center with the capability of planning which platforms will be interrogated before each satellite pass. In this case the



network operation will need an expert operator that should integrate every necessary information to attain efficient and flexible network utilization.

In this paper some issues concerned with a knowledge-based approach to assist the IDCPS network operation are presented and discussed. Some problems concerning the use of knowledge-based technology are presented and it is also proposed a model for the Knowledge-Based Planning Assistant System (KBPAS).

## **2 - USING KNOWLEDGE-BASED TECHNOLOGY**

The knowledge-based approach may play an important role in the development of advanced IDCPS network operation systems, where the integration of multiple and disparate sources of information is needed. Some interesting comments about knowledge-based systems may be found in [3].

### **2.1 - KNOWLEDGE USE IN THE IDCPS NETWORK OPERATION TASK**

In an initial analysis it is suggested that if the IDCPS network is to operate efficiently, it is plausible to assume that expertise will be developed in order to attain near optimal net management. It means that the net and its operation should have an evolutionary design, in which the initial configuration would require a manual interaction (it is expected that an expertise will be created). As the number of IDCPS increase it will be required a computational system to assist the operation, generating an adequate plan (a list of most important IDCPS for the next passage).

For these reasons, all required knowledge will be taken as a "plausible" one, whose initial representation and utilization would be guidelines for the expertise to be acquired subsequently.

### **2.2 - RESPONSE TIME**

An observed drawback of many existing knowledge-based systems is their slow response time. An assistant system for IDCPS operation task has not the requirement of quick response, although this kind of system admits a real-time conception.

The communication between the Ground-Station and the Satellite (to transmit the plan for the next interrogations) will occur when the satellite enters the Ground-Station visibility area. The maximum system response time is the time interval between two passes, which represents a safety margin for the worst case, i.e., the situation in which some information concerned with the last pass will also be taken into account for the next passage plan.

### 2.3 - EXPLANATION CAPABILITY

This explanation capability should support both the system development and operational phases. In the former it will assist the knowledge base debugging, while in the operational phase it would provide facilities to explain:

- \* why a given IDCP was not included in the last generated plan;

- \* which were the most important factors that influenced a certain IDCP selection for a particular passage;

- \* which were the conflicting factors that influenced a certain IDCP selection for a particular passage.

In addition, the system will present the ability to exhibit a detailed trace of the reasoning chains, which is a desirable feature for an assistant system [4]. All these explanation capabilities will result in reports.

It is intended that the system will operate autonomously when the network will be in its full operational status, although the explanation capability will always be available.

### 3 - THE KNOWLEDGE-BASED PLANNING ASSISTANT SYSTEM (KBPAS)

To guide the KBPAS design efforts, it may be guessed a scenario that exemplifies a typical and non-trivial IDCPs interrogation planning problem. This scenario assumes a non-uniform IDCPs density distribution across the Brazilian territory. In a first phase only the Brazilian territory is considered; however if it is assumed some satellite buffering and storing capability other countries could also use these facilities. This scenario is intended to allow the representation and management of typical seasonal meteorological occurrences, abnormal environmental phenomena, failures (partial or total), cloud coverage, transmission power attenuation problems and other circumstantial factors.

A simplified model of the KBPAS which is the basis for this study is shown in Figure 1. Its overall structure comprises five major components: the user interface, the IDCPs past plans base, the high and low level planners, the knowledge base and the database.

The user interface should be designed to easily display IDCP network operation information, such as the IDCPs and satellite geographic positions, the status and graphs of relevant parameters, and warning indicators.

The user may have access to reports showing either IDCPs proposed plans in past passages or the plan inferred for the

next pass, permitting in this way "a posteriori" plan analysis; in addition, the user would be allowed to alter directly the plans at any of the two planning levels.

The knowledge base and reasoning: considering the complexity of the information upon which operation techniques are based, an organizational framework for this information is recommended, in which it will be integrated taking into account the uncertainty and the need of an indexing structure.

Basically, the IDCPS will be distributed across regions in the states (or even sub-regions) as needed. The scattering of the IDCPS at the Brazilian territory will entail a non-uniform density, and at each pass the satellite visibility area will cover partially this IDCPS network. Besides this available information in the database, there will also be the message length, the repetition period, etc.

The IDCPS in the network may be requested by its features, such as the particular area where they are placed, their label as they are related to their applications (hydrological, meteorological or snow data stations), etc.

The types of requisition available are related to:

- \* abnormal environmental phenomena monitoring (forest fire, drought, flood, hoar-frost or snow, pollution, intense hot weather, etc);

- \* normal experimental needs (e.g., meteorological studies);

- \* particular needs (e.g., strategic);

- \* the impossibility of data collecting in past passages (partial or total IDCPS failures, satellite temporary problems);

- \* global and local atmospheric research programs.

It is envisaged a priority scheme that may rule out conflicts between competing requisitions.

Each plan to be generated is concerned with the next satellite pass. The high level planner should reason in a data-driven way generating a list of IDCPS that should be interrogated along the next passage, one station at a time. An embedded feature of the program that generates the plans is to take into account the information about which IDCPS were accessed and did not answer as expected.

That list of IDCPS is then passed to the low level planner that must order it on adequate time intervals by incorporating

the information of satellite position along its orbit, and transform it in an effective sequence of telecommands that should be transmitted to the satellite.

The already executed plans may be stored in the past plans base by specifying the date, the orbit data and the high and low level plan representations. This information may permit some plan statistics or the analysis of a particular plan.

The initial IDCPS information to be integrated is shown in Table 1.

#### 4 - CONCLUDING REMARKS

As it was pointed out earlier, this study was aimed at investigating the feasibility of a knowledge-based system to assist the IDCPS network operation. It is believed that the use of knowledge-based techniques may greatly expand the capabilities of the satellite-based environmental data collecting system, and can give flexibility in the evolutionary aspect of the IDCPS network operation system development.

#### REFERENCES

- [1] ROSENFELD, P. MECB Ground segment: systems aspects. A-REV-0030, 1987
- [2] LOCATION AND DATA COLLECTION SATELLITE SYSTEM USER'S GUIDE SERVICE ARGOS
- [3] WATERMAN, D. A. A guide to expert system. Reading, K.A., Addison-Wesley, 1986
- [4] BUCHANAN, B. G. ; SHORTLIFE, E. H. Rule-based expert systems. Addison-Wesley, Reading, Mass. 1985

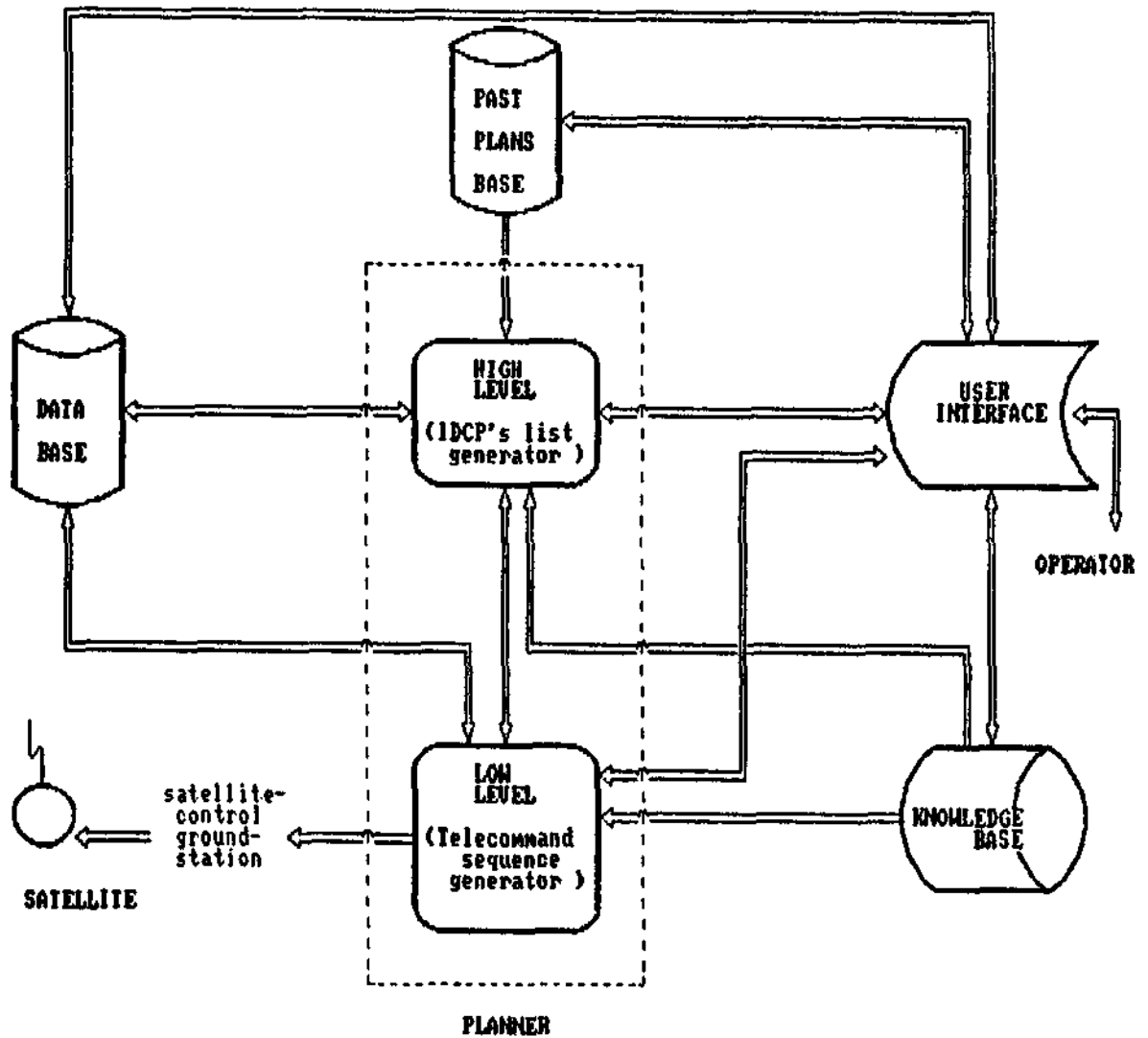

Figure 1 - The KBPAS architecture and ground-station facilities.

TABLE 1 - THE IDCP PARAMETER INFORMATION

<u>Parameters</u>	<u>Value</u>
1. Cloud coverage expected at the IDCP position for the next satellite passage.	cover/clear
2. The IDCP position in the satellite visibility area for the next passage.	within/out
3. The IDCP position in the satellite visibility area for the second next passage	within/out
4. Indicator if IDCP data was received during the last satellite pass.	yes/no
5. The environmental phenomenon type at the DCP location .	normal/abnormal
6. The kind of normal environmental phenomenon at the DCP location.	one of the possible meteorological/ climatological phenomena (rain, snow, etc)
7. The priority assigned to each IDCP (three priority degrees).	low/medium/high
8. The IDCPs spatial density in its surrounding (for example: number of IDCPs present in a limited area).	numerical
9. The IDCP operational status.	normal/partial failure/total failure
10. The IDCP operation life time after its installation (it suggests failure possibility and power transmission level attenuation).	short/long

<u>Parameters</u>	<u>Value</u>
11. The expected IDCP repetition period. It is the time interval between two consecutive messages. It must be chosen in order to allow a sufficient data sampling.	numerical
12. The IDCP message duration. It is the sensor data string duration time. It depends on the number of sensors connected to the IDCP.	numerical
13. The IDCP last reception date (the time interval between this date and the next pass is a plausible indicator of the environmental data sampling rate).	numerical
14. The successful IDCPs reception rate (it is compared with the expected sampling rate).	numerical
15. The specific demand for receiving data from the IDCP.	yes/no



PROPOSTA PARA  
PUBLICAÇÃO

- DISSERTAÇÃO  
 TESE  
 RELATÓRIO  
 OUTROS

TÍTULO			
Trazendo a Knowledge - based system to assist the Brazilian data-collecting system operation			
IDENTIFICAÇÃO	AUTOR(ES)		ORIENTADOR
	Valter Rodrigues P.O. Simioni P.P.B. Oliveira C.A. de Oliveira C.A.M. Hoffmann		
	CO-ORIENTADOR		
	DIVULGAÇÃO		
LIMITE	DEFESA	CURSO	ORGÃO
—/—/—	—/—/—		
		<input checked="" type="checkbox"/> EXTERNA <input type="checkbox"/> INTERNA <input type="checkbox"/> RESTRITA <input checked="" type="checkbox"/> CONGRESSO <input type="checkbox"/> REVISTA <input type="checkbox"/> OUTROS	
REV. TÉCNICA	NOME DO REVISOR		NOME DO RESPONSÁVEL
			Valter Rodrigues
RECEBIDO	DEVOLVIDO	ASSINATURA	APROVADO
—/—/—	—/—/—		<input checked="" type="checkbox"/> SIM <input type="checkbox"/> NÃO   DATA: 14/9/88
REV. LINGUAGEM	Nº	PRIOR.	RECEBIDO
			—/—/—
NOME DO REVISOR		OS AUTORES DEVEM MENCIONAR NO VERSO INSTRUÇÕES ESPECÍFICAS, ANEXANDO NORMAS, SE HOUVER	
PÁG.	DEVOLVIDO	ASSINATURA	RECEBIDO
—/—/—	—/—/—		14/09/88
		NOME DA DATILÓGRAFA	
		W. Felner	
Nº DA PUBLICAÇÃO:	PÁG.:	AUTORIZO A PUBLICAÇÃO	
CÓPIAS:	Nº DISCO:	LOCAL:	<input type="checkbox"/> SIM <input type="checkbox"/> NÃO   —/—/—

OBSERVAÇÕES E NOTAS