

1. Publication Nº <i>INPE-3393-PRE/664</i>	2. Version	3. Date <i>Jan., 1985</i>	5. Distribution <input type="checkbox"/> Internal <input checked="" type="checkbox"/> External <input type="checkbox"/> Restricted
4. Origin <i>DEN</i>	Program <i>SUPRI</i>		
6. Key words - selected by the author(s) <i>POWER CONDITIONING PHOTOVOLTAIC SYSTEM DC TO DC CONVERTERS</i>			
7. U.D.C.: <i>629.7.064.56:629.783</i>			
8. Title <i>INPE-3393-PRE/664</i> <i>PROPOSED ENERGY SYSTEMS FOR THE BRAZILIAN DATA COLLECTION SATELLITE</i>		10. Nº of pages: <i>12</i>	11. Last page: <i>246</i>
9. Authorship <i>L.J.Faria, R.D. Costa, J.P. Andra de-Filho, C.R.E.R. Dueñas, F.C. de Nadai, C. J.C. Barros, G.J. Adabo, N.M. Tanaka, C.R.G. Morais, A. Francisco Jr., R. Lazarini, N. Shi tara.</i>		12. Revised by <i>Ranvaud</i> <i>Ronald Ranvaud</i>	
Responsible author <i>l.j.faria</i>	13. Authorized by <i>Parada</i> <i>Nelson de Jesus Parada Director General</i>		
14. Abstract/Notes <i>The first satellite of the Brazilian Complete Space Mission will be devoted to Data Collection. Twelve specialists engaged in its energy program have proposed an architecture for the power supply subsystem. Based on a fixed body mounted solar array generator, it has a dual Ni-Cd battery for energy storage and has its bus voltage limited by a shunt regulator. The power is distributed to other subsystems by multiple DC/DC switching converters and a relay based switching unit. All these parts have been developed and are being tested functionally at a prototype level.</i>			
15. Remarks <i>This paper was presented at the IV Nipo-Brasileiro Symposium of Science and Technology, in the Institute for Space Research-INPE, São José dos Campos, SP, Brazil, August 4-6, 1984.</i>			

PROPOSED ENERGY SYSTEMS FOR THE BRAZILIAN DATA COLLECTION

SATELLITE

L.J.FARIA, R.D. COSTA, J.P. ANDRADE-FILHO, C.R.E.R. DUEÑAS,
F.C. DE NADAI, C.J.C. BARROS, G.J. ADABO, N.M. TANAKA,
C.R.G. MORAIS, A. FRANCISCO JR., R. LAZARINI, N. SHITARA.

Department of Space Energy
Instituto de Pesquisas Espaciais - INPE

ABSTRACT

The first satellite of the Brazilian Complete Space Mission will be devoted to Data Collection. Twelve specialists engaged in its energy program have proposed an architecture for the power supply subsystem. Based on a fixed body mounted solar array generator, it has a dual Ni-Cd battery for energy storage and has its bus voltage limited by a shunt regulator. The power is distributed to other subsystems by multiple DC/DC switching converters and a relay based switching unit. All these parts have been developed and are being tested functionally at a prototype level.

1 - INTRODUCTION

The power supply subsystem for the first Brazilian Satellite is being developed using a very simple standard architecture mainly due to the low level power requirements. The system is based on a fixed photovoltaic solar array that covers all external panels of the satellite (excepting its earthward panel).

As an aid to the development, some facilities have been built. A simulation program was used to define and to optimize the design of elements as well as to get the response of the system to various conditions of illumination and energy demand. To carry out the qualification of models and design of circuitry, a workbench with solar array simulator, load simulator and data acquisition and control system was mounted, improved and is now being used successfully.

2 - THE POWER SUPPLY SUBSYSTEM ARCHITECTURE

The power supply subsystem basically consists of a solar array generator, a shunt regulator, a battery charge regulator, two modules of NiCd battery, DC/DC converters and a relay switching unit. Fig. 1 shows the architecture of this system. The solar array is responsible for the electric power generation. Its upper voltage is limited by the shunt regulator reducing the voltage range on the bus and allowing an optimization in the design of the DC/DC converters. The battery charge regulator controls the charge current to the batteries, giving an overvoltage and overtemperature protection for them. The DC/DC converters

regulate the voltage and current level to meet user specifications, having its output switched to users by a relay based unit.

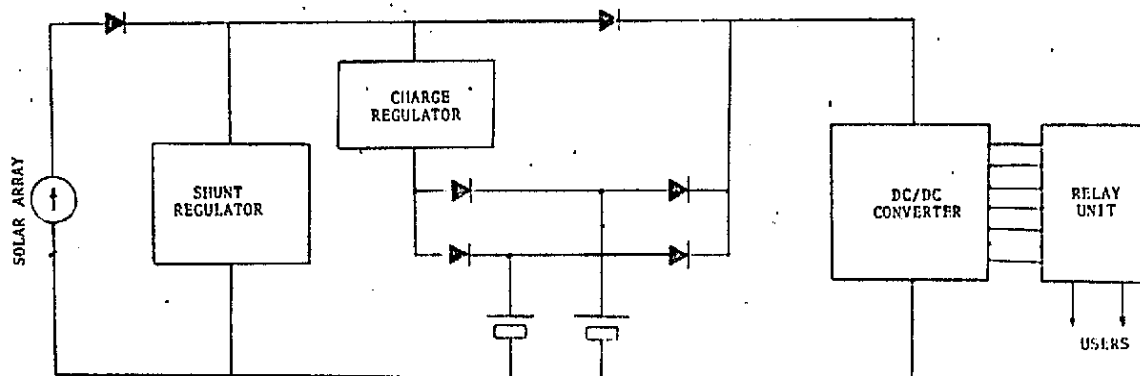

Fig. 1 - Power supply subsystem.

3 - COMPONENT DESCRIPTION

The first Brazilian satellite will be built inside a prismatic body with an octagonal section. The solar array generator is based on 9 fixed panels covering the 8 lateral sides plus the octagonal one, opposite to the earth as shown in figure 2. The lateral panels consist of 4 parallel strings of 68 solar cells in series. The octagonal panel is formed by 10 parallel strings of the same size. The octagonal panel accommodates an RF antenna and an attitude control mast. The antenna and the mast can cast a shadow on the panel which results in a 25% lowering of the average power generated by this panel.

Following are some characteristics of this solar generator:

- Number of cells: $8 \times 4 \times 68 + 1 \times 10 \times 68 = 2856$ cells.
- Cell area: $2 \times 4 \text{ cm}^2$
- Cell type: monocrystalline silicon, N on P cell.
- Cell efficiency: 12% (beginning of life).
- Operation temperature: -65°C to $+70^{\circ}\text{C}$.
- Panel absorptivity and emissivity = 0.88.
- Degradation in 2 years: 15% in power.
- Total mass of the panels: 6kg.

At the end of life the average power generated by this solar array is 48W, considering a 25% loss due to shadow problems on the octogonal panel and 4% loss due to wiring, blocking diodes and cell mismatching.

The shunt regulator component works limiting the array voltage in 25V, avoiding an overvoltage on the bus. This voltage limit corresponds approximately to the maximum power voltage of the solar array at the end of life conditions. Working directly on the bus; the regulator is designed to dissipate up to 40W to maintain the satellite in proper operation.

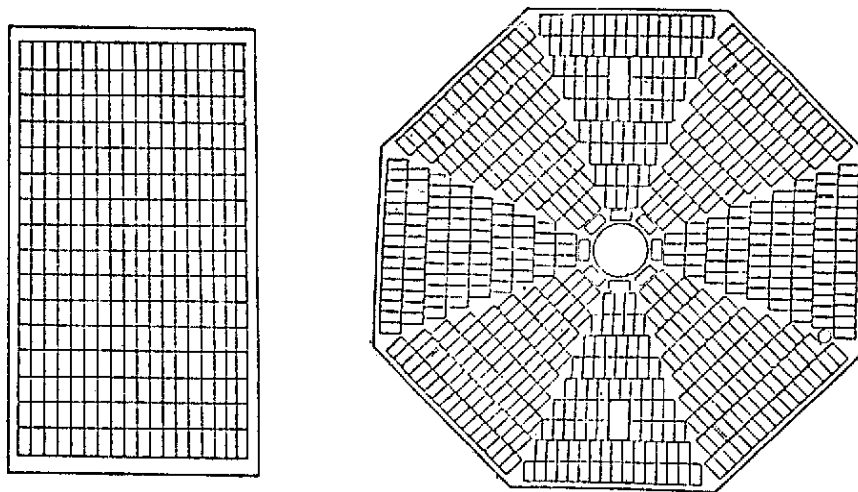

Fig. 2 - Lateral and octagonal panel cell distribution.

In so far as the battery charge regulator is concerned, it will operate in one of the two following modes: constant current or trickle charge. The constant voltage mode has not been considered necessary due to the short duration of the mission. The constant current charge mode corresponds to a C/7 current charge, where "C" stands for the battery cell nominal charge. The trickle charge mode satisfies a C/50 condition. The end of charge voltage for the constant current charge mode is 24V, corresponding to 1.5V per battery cell. Reaching this point, the regulator changes its charge mode to the trickle charge.

The batteries are constituted by two modules of 16 NiCd-4Ah, nominal-cells, connected in series. These modules are connected in parallel but can operate isolated in case of failure. The depth of discharge foreseen is 12% and the

environment temperature must be maintained between 0°C and 20°C. The expected efficiencies in current and power are 87% and 75%, respectively. The batteries should support approximately 11.000 charge/discharge cycles, corresponding to 2 years of mission.

The DC/DC converters are used to keep the output level of voltage or current as required by others subsystems. The conversion unit characteristic data are presented in Table 1. The design adopted for conversion uses high frequency pulse width modulation switching regulators. Three different schemes of converters are used: the buck type converter is used for positive 5V and 15V voltages together with current regulators; the push-pull type is used for the positive 18V voltage regulator - it is required because this voltage

TABLE 1
CONVERSION UNIT CHARACTERIST DATA

OUTPUT	MAXIMUM POWER (W)	MINIMUM POWER (W)	REGULATION %	RIPPLE mVp-p	NOISE mVp-p	EFFICIENCY %
+5V	10	2	1	50	100	75
-5V	1	0.2	1	50	100	85
+15V	20	4	1	50	100	85
-15V	5	1	1	50	100	90
+18V	10	2	1	100	200	80
300mA	3x0.3	0.3	1.5	5mA	5mA	40

is in the voltage range of the bus; finally the flyback type converters are used for the negative 5V and 15V voltages. These options have shown to be the best configuration considering mainly efficiency, regulation and noise factors. To keep the requirements of the I²L logic used by the on board supervisor a regulated current converter was designed. One important aspect to be considered is that, although the power level required by the current converter is low, the very low efficiency can disturb the global conversion efficiency, mainly during the no-service period, when the power demand required is reduced. The average efficiency specified for the conversion unit is 75%.

Completing the power supply subsystem, a relay based unit is used to switch the power as required by the demand of each energy consumer. Two control signals can actuate on this unit: direct from earth telecommands or by the on board supervisor. To execute its functions magnetic latching type relays have been specified in a way to avoid a continuous energy consumption on driving.

Due to the high level reliability required for the power supply, some considerations have been made in the design of the power supply subsystem. As a design requirement all components should work even in case of one internal failure. Also, double redundancy has been specified for critical components like the battery charge regulator and the conversion unit. Another reliability consideration is related to the switching unit where two active signals should be received before the command function can be activated.

4 - ORBIT ENERGY BALANCE

The Brazilian satellite will fly in a circular near equatorial orbit with a height of 700km and an inclination of 25° . Whithin such conditions, it will have 99 minutes period and 35 minutes maximum duration night. Also, considering a single earth station (Cuiabá/Brazil), the maximum service time should be of 12,5 minutes.

Using the night operation as the energy balance worst case, it is possible to calculate the energy balance for one orbit. Figure 3a shows the shape for the energy supplied by the solar array. The average power generated can be estimated then as 48W. Considering this power and the worst case, a diagram for the generated and dissipated energy during one orbit can be drawn (Fig. 3b) showing the energy stored in the batteries and the necessary consumption to supply the satellite during a night period.

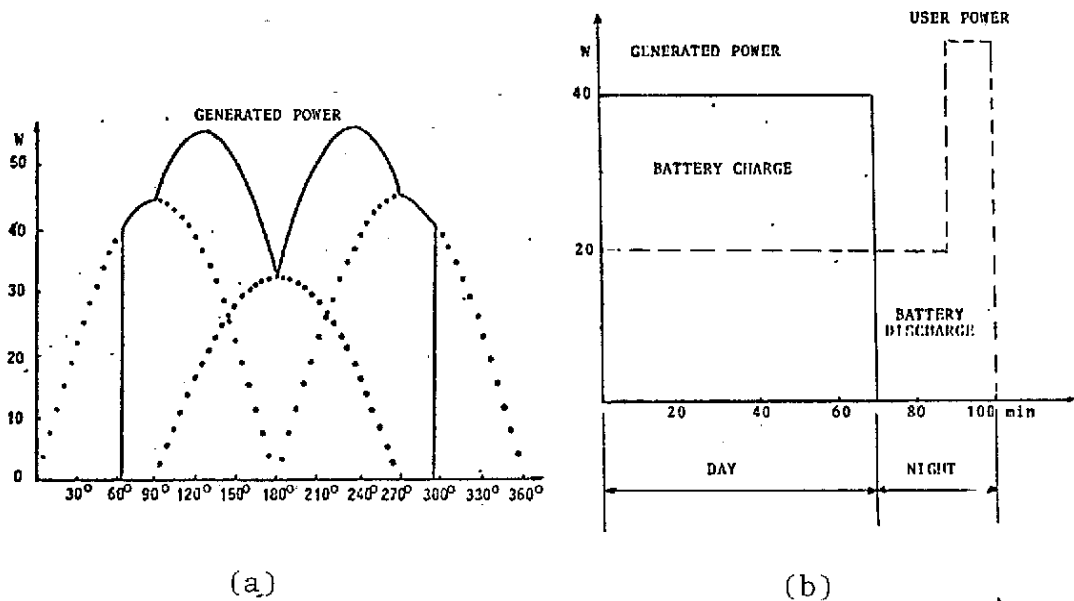

Fig. 3 - a) Generated power diagram.

b) The worst case generated and used energy diagram.

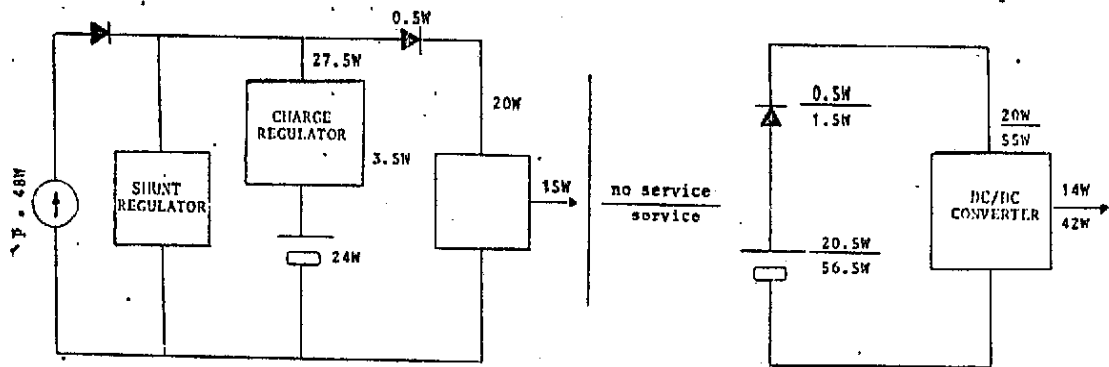

Fig. 4 - a) No-operation day power budget.

b) Operation/no-operation night power budget.

TABLE 2

POWER SUPPLY NIGHT PERIOD POWER BUDGET

	Non Service (22.5min)		Service (12.5min)		Total E(Wh)
	P(W)	E(Wh)	P(W)	E(Wh)	
Converter	-20.0	-7.5	-55.0	-11.5	-19.0
Discharge diodes	-0.5	-0.2	-1.5	-0.3	-0.5
Batteries	+20.5	+7.7	+56.5	+11.8	+19.5

From Fig. 4A, it is possible to determine the net energy stored in the batteries during day time as:
 $24W \times 65min = 26Wh$. Considering a power efficiency of 75% for the batteries, the available energy is approximately 20Wh. Figure 4b shows the power consumption during night with a period of operation. The energy dissipated can be calculated as 19.5Wh (Table 2).

These calculations show that at the end of life conditions, there is no energy margin to work with.

Considering that some data are conservative, it is expected to have them improved so as to end up with positive energy margin.

5 - CONCLUSION

A power supply subsystem has been developed to supply the necessary energy for the first Brazilian satellite. Some initial conditions like satellite dimensions and service/no-service power consumption of subsystems were specified as project requirements. Using a simple architecture and imposing performances for some elements like efficiency for solar cells and converters, a power supply subsystem with a positive energy balance has been developed.

6 - REFERENCES

- . MECB - ANÁLISE DE PROBLEMAS DE INTERFACE E DESCRIÇÃO ATUALIZADA DO SEGMENTO ESPACIAL DA MECB/COLETA DE DADOS - São José dos Campos, SP, INPE, Set. 1983.
- . ANDRADE FILHO, J.P. - "SIMULAÇÃO DE UM SISTEMA DE SUPRIMENTO DE ENERGIA DE UM SATÉLITE". Dissertação de Mestrado, São José dos Campos, SP, INPE, Jun. 1984. (INPE-3140-TDL/166).
- . BARROS, C.J.C.; ADABO, G.J. - "CÁLCULO PARA ESPECIFICAÇÃO PRELIMINAR DO GERADOR SOLAR DO SATÉLITE DE COLETA DE DADOS" - DSU nº 07/84, São José dos Campos, SP, INPE, Jul. 1984.
- . TANAKA, N.M. - "UNIDADE DE CONDICIONAMENTO E ARMAZENAMENTO" - Rel. Int. DSU nº 04/84 - São José dos Campos, SP, INPE, Jul. 1984.
- . MEDEIROS, U.M. - "INSOLAÇÃO DO SATÉLITE DE COLETA DE DADOS SOB O PONTO DE VISTA DA GEOMETRIA ORBITAL PARA OTIMIZAÇÃO DO APROVEITAMENTO DE ENERGIA" - São José dos Campos, SP, INPE, Set. 1982.