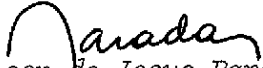

1. Classification <i>INPE-COM.4/RPE</i> <i>C.D.U. 533.9</i>	2. Period	4. Distribution Criterion internal <input type="checkbox"/> external <input checked="" type="checkbox"/>
3. Key Words (selected by the author) <i>PARTICLE INTERACTIONS</i> <i>BOLTZMANN EQUATION</i> <i>FOKKER-PLANCK EQUATION</i>		
5. Report Nº <i>INPE-1606-RPE/082</i>	6. Date <i>October, 1979</i>	7. Revised by  <i>V. W. J. H. Kirchhoff</i>
8. Title and Sub-title <i>THE BOLTZMANN AND THE FOKKER-PLANCK EQUATIONS</i>		9. Authorized by  <i>Nelson de Jesus Parada</i> Director
10. Sector <i>DCE</i>	Code	11. Nº of Copies <i>10</i>
12. Authorship <i>J. A. Bittencourt</i>		14. Nº of Pages <i>69</i>
13. Signature of the responsible <i>Bittencourt.</i>		15. Price
16. Summary/Notes <i>This chapter presents a derivation of the Boltzmann collision integral, which applies to the case of binary collisions in a dilute gas, and of the Fokker-Planck collision term, which applies to the case of multiple Coulomb interactions in a plasma. The assumptions involved in the derivation of the Boltzmann collision integral, and its irreversible character, are discussed in detail. An analysis of Boltzmann's H theorem and a derivation of the equilibrium Maxwell-Boltzmann distribution function, based on a maximum entropy approach, are also presented. An approximate expression for the Boltzmann collision term, valid for a weakly ionized plasma, is obtained through a spherical harmonic expansion of the distribution function. Next, the Fokker-Planck equation is derived, starting from the Boltzmann collision integral. Finally, the Fokker-Planck coefficients are calculated for the Coulomb interaction and applied to the case of electron-ion collisions.</i>		
17. Remarks		

INDEX

CHAPTER 21

THE BOLTZMANN AND THE FOKKER-PLANCK EQUATIONS

List of Figures	v
1. <u>Introduction</u>	1
2. <u>The Boltzmann Equation</u>	2
2.1 - Derivation of the Boltzmann collision integral	2
2.2 - Jacobian of the transformation	9
2.3 - Assumptions in the derivation of the Boltzmann collision integral	12
2.4 - Rate of change of a physical quantity as a result of collisions	15
3. <u>The Boltzmann's H Function</u>	17
3.1 - Boltzmann's H theorem	19
3.2 - Analysis of Boltzmann's H theorem	22
3.3 - Maximum entropy or minimum H approach for deriving the equilibrium distribution function	26
3.4 - Mixture of various species of particles	29

4. <u>Boltzmann Collision Term for a Weakly Ionized Plasma</u>	30
4.1 - Spherical harmonic expansion of the distribution function.	31
4.2 - Approximate expression for the Boltzmann collision term ..	33
4.3 - Rate of change of momentum due to collisions	37
5. <u>The Fokker-Planck equation</u>	39
5.1 - Derivation of the Fokker-Planck collision term	39
5.2 - The Fokker-Planck coefficients for Coulomb interactions ..	46
5.3 - Application to electron-ion collisions	55
<u>Problems</u>	57

LIST OF FIGURES

Fig. 1 - The volume element of height $g dt$ and cross sectional area $b db d\epsilon$, with sides lying between b and $b + db$, and between ϵ and $\epsilon + d\epsilon$	5
Fig. 2 - When the gas satisfies the condition of molecular chaos, the function $H(t)$ is at a local maximum, indicated here by the point denoted (2)	25
Fig. 3 - The time evolution of $H(t)$ for a gas initially not in an equilibrium state is indicated by the solid curve. The dashed curve is the time variation of $H(t)$ predicted by the Boltzmann equation. The dots indicate some of the instants when the condition of molecular chaos is satisfied	26
Fig. 4 - Spherical coordinates (v, θ, ϕ) in velocity space	32
Fig. 5 - Illustrating the processes of dynamical friction and diffusion in velocity space	46

CHAPTER 21

THE BOLTZMANN AND THE FOKKER-PLANCK EQUATIONS

1. INTRODUCTION

When the Boltzmann equation was first introduced in Chapter 5, the effects of collisions were incorporated in its right-hand side [see Eq. (5.5.27)] through a general collision term $(\delta f_\alpha / \delta t)_{\text{coll}}$, still to be specified. We present now a derivation of the Boltzmann collision term, which takes into account only binary collisions. This collision term involves integrals over the particle velocities, so that the Boltzmann equation turns out to be an *integro-differential equation*. The fact that the Boltzmann collision integral takes into account only binary collisions limits considerably its applicability for a plasma, where each charged particle interacts simultaneously with a large number of neighboring charged particles. Although these multiple Coulomb collisions are very important for a plasma, there are some cases, however, as in weakly ionized plasmas, where the binary charged-neutral collisions play a dominant role.

The collision term originally proposed by Boltzmann applies to a gas of low density, in which only binary elastic collisions are important. These binary collisions may involve neutral atoms or molecules in a dilute gas, or charged and neutral particles in a plasma. We have seen that in a plasma these are not the only particle interactions of importance. The

multiple Coulomb interactions need to be taken into account and in most cases are much more important than the binary collisions. Nevertheless, the Boltzmann collision term can in some cases be used for a plasma, but the results obtained have to be interpreted cautiously. Furthermore, the Fokker-Planck collision term, which applies to charged particle interactions, can be derived from the Boltzmann collision term by considering the charged particle encounters as a series of consecutive weak (small deflection angle) binary collisions.

2. THE BOLTZMANN EQUATION

2.1 - Derivation of the Boltzmann collision integral

The collision term, $(\delta f_\alpha / \delta t)_{\text{coll}}$, represents the rate of change of the distribution function, $f_\alpha(\underline{r}, \underline{v}, t)$, as a result of collisions between the particles. Some of the particles of type α originally situated inside the volume element $d^3r d^3v$ at $(\underline{r}, \underline{v})$ in phase space may leave this volume element, whereas some particles of type α originally outside the volume element may enter it, as a result of collisions during the time interval dt . Let ΔN_α denote this net gain or loss of particles of type α in $d^3r d^3v$ at $(\underline{r}, \underline{v})$ during dt , that is,

$$\Delta N_\alpha = \left(\frac{\delta f_\alpha}{\delta t} \right)_{\text{coll}} d^3r d^3v dt \quad (2.1)$$

It is convenient to separate ΔN_α into two parts

$$\Delta N_{\alpha} = \Delta N_{\alpha}^{+} - \Delta N_{\alpha}^{-} \quad (2.2)$$

where ΔN_{α}^{+} represents the gain term due to collisions in which a particle of type α situated inside d^3r about \underline{r} has, *after* collision, a velocity lying within d^3v at \underline{v} , and ΔN_{α}^{-} represents the loss term due to collisions in which a particle of type α situated inside d^3r about \underline{r} has, *before* collision, a velocity lying within d^3v at \underline{v} .

We proceed now to determine ΔN_{α} , defined in Eq. (2.1), by calculating initially ΔN_{α}^{-} and afterwards ΔN_{α}^{+} .

To calculate ΔN_{α}^{-} we consider the particles of type α situated within the volume element d^3r at \underline{r} , whose velocities lie within d^3v about \underline{v} , and which are scattered out of this velocity range as a result of collisions with particles of some type β (which may or may not be type α particles) lying in the *same* volume element d^3r at \underline{r} , and having some velocity within d^3v_1 about \underline{v}_1 . Let us focus attention on a single particle of type α situated within the volume element of phase space $d^3r d^3v$ at the coordinates $(\underline{r}, \underline{v})$. The particles of type β inside $d^3r d^3v_1$ at $(\underline{r}, \underline{v}_1)$ may be viewed as constituting a particle flux incident on this particle of type α . Noting that $f_{\beta}(\underline{r}, \underline{v}_1, t) d^3v_1$ is the number of type β particles per unit volume, with velocities within d^3v_1 about \underline{v}_1 , the flux of this incident beam can be written as

$$\Gamma_{\beta} = f_{\beta}(\underline{r}, \underline{v}_1, t) d^3v_1 |\underline{v}_1 - \underline{v}| = f_{\beta}(\underline{r}, \underline{v}_1, t) d^3v_1 g \quad (2.3)$$

Consider the type β particles which approach with an impact parameter between b and $b + db$, in a collision plane lying between the angles ϵ and $\epsilon + d\epsilon$. The average number of interactions of this part of the type β particles with the type α particle, occurring in the time interval dt , is equal to the number of particles crossing the element of area $b db d\epsilon$ during dt . This number can be obtained by multiplying the flux of type β particles, given in (2.3), by the element of area $b db d\epsilon$ and by the time interval dt ,

$$\Gamma_{\beta} b db d\epsilon dt = f_{\beta}(\underline{r}, \underline{v}_1, t) d^3v_1 g b db d\epsilon dt \quad (2.4)$$

This expression is just the number of particles of type β with velocities within d^3v_1 about v_1 , lying inside the elementary cylindrical volume of length $g dt$ and cross sectional area $b db d\epsilon$, shown in Fig. 1, and whose volume is $g b db d\epsilon dt$. It is assumed here that dt is large compared to the time of interaction between the colliding particles. To determine the number of collisions between the indicated part of the type β particles with all the type α particles lying within $d^3r d^3v$ at $(\underline{r}, \underline{v})$, during dt , we multiply Eq. (2.4) by $f_{\alpha}(\underline{r}, \underline{v}, t) d^3r d^3v$, the number of particles of type α lying within the volume element of phase space $d^3r d^3v$ at $(\underline{r}, \underline{v})$,

$$f_{\alpha}(\underline{r}, \underline{v}, t) d^3r d^3v f_{\beta}(\underline{r}, \underline{v}_1, t) d^3v_1 g b db d\epsilon dt \quad (2.5)$$

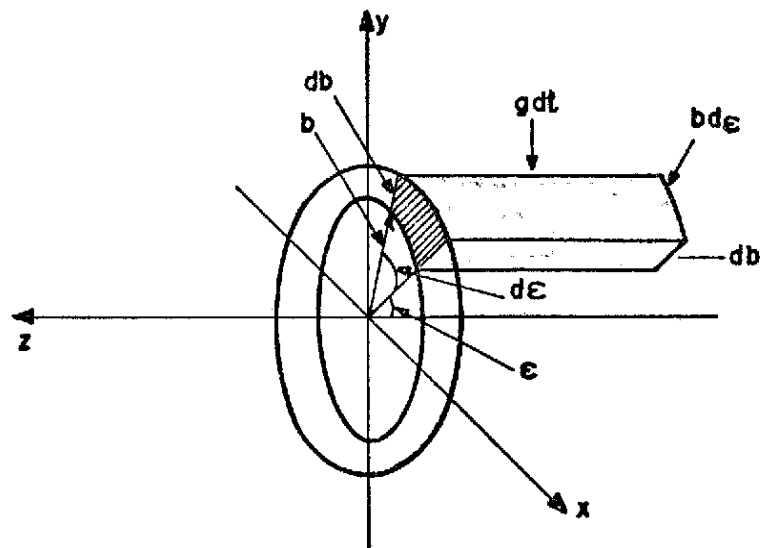

Fig. 1 - The volume element of height $g dt$ and cross sectional area $b db d\epsilon$, with sides lying between b and $b + db$, and between ϵ and $\epsilon + d\epsilon$

In deducing this expression it has been assumed that the number of particles of the types α and β , with velocities in d^3v about \underline{v} , and d^3v_1 about \underline{v}_1 , respectively, lying in the same volume element d^3r about \underline{r} , is proportional to the product $f_\alpha(\underline{r}, \underline{v}, t) f_\beta(\underline{r}, \underline{v}_1, t)$. However, in a system of interacting particles the existence of a particle within a given volume element d^3r at \underline{r} , with a given velocity \underline{v} , affects the probability that another particle be found with a specified velocity \underline{v}_1 in the same volume element d^3r , at the same instant of time. Thus, in expression (2.5) we are neglecting any possible correlation that may exist between the velocity of a particle and its position. This approximation, known as the *molecular chaos* assumption, is introduced as a mathematical convenience, but although it may represent a possible condition for a system of particles, it is not a general condition.

The total number of particles of type α in d^3r about \underline{r} that are scattered *out* of the velocity space element d^3v about \underline{v} , during dt , is obtained integrating expression (2.5) over all possible values of b , ϵ and \underline{v}_1 , and summing over all species β

$$\Delta N_{\alpha}^{-} = f_{\alpha}(\underline{r}, \underline{v}, t) d^3r d^3v dt \sum_{\beta} \int_{\underline{v}_1} \int_b \int_{\epsilon} f_{\beta}(\underline{r}, \underline{v}_1, t) d^3v_1 g b db d\epsilon \quad (2.6)$$

where the triple integral over \underline{v}_1 is represented again by a single integral sign.

To determine the *gain* term, ΔN_{α}^{+} , we proceed in a way similar to the determination of ΔN_{α}^{-} , by considering the *inverse collision*, in which a particle of type α with initial velocity in d^3v' about \underline{v}' collides with a particle of type β having initial velocity in $d^3v'_1$ about \underline{v}'_1 , resulting in the particle of type α scattered into the velocity element d^3v about \underline{v} , the event occurring inside the volume element d^3r about \underline{r} . The average number of interactions between a single particle of type α , inside the volume element of phase space $d^3r d^3v'$ at $(\underline{r}, \underline{v}')$, with the particles of type β inside $d^3r d^3v'_1$ at $(\underline{r}, \underline{v}'_1)$, which approach with an impact parameter between b and $b + db$, and with the collision plane oriented between the angles ϵ and $\epsilon + d\epsilon$, is given by

$$f_{\beta}(\underline{r}, \underline{v}'_1, t) d^3v'_1 g' b db d\epsilon dt \quad (2.7)$$

To take into account all collisions occurring within d^3r at \underline{r} , during the time interval dt , between the particles of type α and type β which scatter the particles of type α into the volume element d^3v about \underline{v} , we must multiply (2.7) by the number of particles of type α which lie initially inside $d^3r d^3v'$ at $(\underline{r}, \underline{v}')$, that is $f_\alpha(\underline{r}, \underline{v}', t) d^3r d^3v'$, integrate the result over all possible values of b , ϵ and \underline{v}_1 , and sum over all species β ,

$$\Delta N_\alpha^+ = f_\alpha(\underline{r}, \underline{v}', t) d^3r d^3v' dt \sum_\beta \int_{v_1} \int_b \int_\epsilon f_\beta(\underline{r}, \underline{v}_1, t) d^3v_1 g' b db d\epsilon \quad (2.8)$$

We have seen that $g' = g = |\underline{v}_1 - \underline{v}|$, and from the theory of Jacobians

$$d^3v' d^3v_1' = |J| d^3v d^3v_1 \quad (2.9)$$

It is shown in the following subsection that for this transformation of velocities we have $|J| = 1$, so that

$$d^3v' d^3v_1' = d^3v d^3v_1 \quad (2.10)$$

and Eq. (2.8) becomes

$$\Delta N_\alpha^+ = f_\alpha(\underline{r}, \underline{v}', t) d^3r d^3v dt \sum_\beta \int_{v_1} \int_b \int_\epsilon f_\beta(\underline{r}, \underline{v}_1, t) d^3v_1 g b db d\epsilon \quad (2.11)$$

If we now combine the expressions for ΔN_{α}^{-} and ΔN_{α}^{+} , and substitute $b \, db \, d\varepsilon = \sigma(\Omega) \, d\Omega$, we obtain the following expression for the Boltzmann collision integral

$$\begin{aligned} \left(\frac{\delta f_{\alpha}}{\delta t} \right)_{\text{coll}} &= \left(\frac{\Delta N_{\alpha}^{+} - \Delta N_{\alpha}^{-}}{d^3r \, d^3v \, dt} \right) \\ &= \sum_{\beta} \int_{v_1} \int_{\Omega} (f'_{\alpha} f'_{\beta_1} - f_{\alpha} f_{\beta_1}) \, d^3v_1 \, g \, \sigma(\Omega) \, d\Omega \quad (2.12) \end{aligned}$$

where we have used the notation

$$f'_{\alpha} = f_{\alpha}(\underline{r}, \underline{v}', t)$$

$$f'_{\beta_1} = f_{\beta}(\underline{r}, \underline{v}'_1, t)$$

$$f_{\alpha} = f_{\alpha}(\underline{r}, \underline{v}, t)$$

$$f_{\beta_1} = f_{\beta}(\underline{r}, \underline{v}_1, t)$$

In explicit form, the Boltzmann equation can finally be written as

$$\frac{\partial f_{\alpha}}{\partial t} + \underline{v} \cdot \underline{\nabla} f_{\alpha} + \underline{a} \cdot \underline{\nabla}_v f_{\alpha} = \sum_{\beta} \int_{v_1} \int_{\Omega} (f'_{\alpha} f'_{\beta_1} - f_{\alpha} f_{\beta_1}) \, d^3v_1 \, g \, \sigma(\Omega) \, d\Omega \quad (2.14)$$

The Boltzmann equation is therefore an *integro-differential* equation, involving integrals and partial derivatives of the distribution function. The external force, $\underline{F} = m_{\alpha} \underline{a}$, in the case of a plasma, includes also the electromagnetic Lorentz force, $\underline{F} = q_{\alpha} (\underline{E} + \underline{v} \times \underline{B})$, due to externally applied fields.

For a system consisting of various different species of particles, there is one equation for each species. For an ionized gas composed of electrons, one type of positive ions and one type of neutral particles, for example, we have a system of three Boltzmann equations coupled through the collision term. In the Boltzmann equation for the electrons, for example, the collision term contains the distribution function for the electrons, f_e , the distribution function for the ions, f_i , and the distribution function for the neutral particles, f_n . Since the collision term involves products of the distribution functions, the Boltzmann equation is also *nonlinear*. For a system consisting of only one type of particles the summation over the type β particles disappears, and the collision term involves only the product of distribution functions of the same particle species.

2.2 - Jacobian of the transformation

The relation between the velocity elements d^3v d^3v_1 and d^3v' $d^3v'_1$ is given by

$$d^3v' d^3v'_1 = |J| d^3v d^3v_1 \quad (2.15)$$

where J is the Jacobian of the transformation from the variables $(\underline{v}, \underline{v}_1)$ to $(\underline{v}', \underline{v}'_1)$,

$$J = \frac{\partial(\underline{v}', \underline{v}'_1)}{\partial(\underline{v}, \underline{v}_1)} = \frac{\partial(v'_x, v'_y, v'_z, v'_{1x}, v'_{1y}, v'_{1z})}{\partial(v_x, v_y, v_z, v_{1x}, v_{1y}, v_{1z})} \quad (2.16)$$

which corresponds to the determinant

$$J = \begin{vmatrix} \frac{\partial v'_x}{\partial v_x} & \frac{\partial v'_y}{\partial v_x} & \dots & \frac{\partial v'_{1z}}{\partial v_x} \\ \frac{\partial v'_x}{\partial v_y} & \frac{\partial v'_y}{\partial v_y} & \dots & \frac{\partial v'_{1z}}{\partial v_y} \\ \dots & \dots & \dots & \dots \\ \frac{\partial v'_x}{\partial v_{1z}} & \frac{\partial v'_y}{\partial v_{1z}} & \dots & \frac{\partial v'_{1z}}{\partial v_{1z}} \end{vmatrix} \quad (2.17)$$

Using Eqs. (20.2.5) and (20.2.6) we can express d^3v and d^3v_1 in terms of d^3c_0 and d^3g ,

$$d^3v \, d^3v_1 = |J_c| \, d^3c_0 \, d^3g \quad (2.18)$$

where J_c denotes the Jacobian of the transformation indicated in Eqs. (20.2.5) and (20.2.6). Let us consider initially only the x-component of (2.18),

$$dv_x dv_{1x} = \left| \frac{\partial(v_x, v_{1x})}{\partial(c_{ox}, g_x)} \right| dc_{ox} dg_x \quad (2.19)$$

From Eqs. (20.2.5) and (20.2.6) we obtain

$$\begin{aligned} dv_x dv_{1x} &= \begin{vmatrix} 1 & -\mu/m \\ 1 & \mu/m_1 \end{vmatrix} dc_{ox} dg_x \\ &= \mu \left(\frac{1}{m_1} + \frac{1}{m} \right) dc_{ox} dg_x \\ &= dc_{ox} dg_x \end{aligned} \quad (2.20)$$

Taking the product of three such terms, corresponding to the components x, y, z, gives

$$d^3v d^3v_1 = d^3c_o d^3g \quad (2.21)$$

In a similar way, using Eqs. (20.2.8) and (20.2.9) we find

$$d^3v' d^3v_1' = d^3c_0' d^3g' \quad (2.22)$$

We have seen that $\underline{c}_0 = \underline{c}_0'$. Furthermore, \underline{g} and \underline{g}' differ only in direction, having the same magnitude, and since volume elements are not changed by a simple rotation of coordinates, we must have $d^3g = d^3g'$. Consequently, (2.21) and (2.22) imply

$$d^3v d^3v_1 = d^3v' d^3v_1' \quad (2.23)$$

2.3 - Assumptions in the derivation of the Boltzmann collision integral

The derivation of the Boltzmann collision integral involves four basic assumptions:

- (a) The distribution function does not vary appreciably over a distance of the order of the range of the interparticle force law, as well as over time scales of the order of the interaction time.
- (b) Effects of the external force, on the magnitude of the collision cross section, are ignored.
- (c) Only binary collisions are taken into account.
- (d) The velocities of the interacting particles, before collision, are assumed to be uncorrelated.

The first assumption is quite reasonable and is incorporated in the calculation of $(\delta f_\alpha / \delta t)_{\text{coll}}$ when we evaluate all the distribution functions at the position \underline{r} and at the instant t .

The element of volume d^3r is considered to be large compared to the range of the interparticle forces, and the time interval dt is taken to be large compared to the time of interaction. On the other hand, as far as variations in the distribution functions are concerned, the elements d^3r and dt must be infinitesimally small quantities.

Next, the external force was assumed to have a negligible effect on the two-body collision problem. This is valid if the external force is negligibly small compared to the force of interaction between the particles. When external forces of magnitude comparable to the short-range interparticle forces are present, the collision process is modified. The constancy of the relative speed $g = |\underline{v}_1 - \underline{v}_2|$ is valid only in the absence of external forces.

The assumption of binary collisions is justified for a dilute gas, whose molecules interact through short-range forces. However, it is not strictly valid for a plasma, where the Coulomb force between the charged particles is a long range force. In a plasma a charged particle interacts simultaneously with all the charged particles inside its Debye sphere. Since there is a large number of charged particles inside a Debye sphere, each charged particle in the plasma does not move freely, as does a neutral particle between collisions, but is permanently interacting with a large number of charged particles. Each long-range individual interaction, however, results only in a small deflection in the particle trajectory. Since each individual interaction is relatively weak, the collective effect of many simultaneous interactions can be considered as a cumulative succession of weak binary

collisions. Thus, in general, the Boltzmann collision term is not strictly valid for a plasma and the results obtained for the case of charged-neutral particle interactions in weakly ionized plasmas must be interpreted cautiously.

Assumption (d) is known as the *molecular chaos* assumption. It is justified for a gas in which the density is sufficiently small, so that the mean free path is much larger than the characteristic range of the interparticle forces. This is certainly not a general situation for a plasma, in view of the long-range characteristic of the Coulomb force. Generally, the *joint* probability of having, at the position \underline{r} and at the instant t , a particle of type α with velocity \underline{v} and a particle of type β with velocity \underline{v}_1 , is proportional to

$$f_{\alpha}(\underline{r}, \underline{v}, t) f_{\beta}(\underline{r}, \underline{v}_1, t) [1 + \psi_{\alpha\beta}(\underline{v}, \underline{v}_1, \underline{r}, t)] \quad (2.24)$$

where $\psi_{\alpha\beta}(\underline{v}, \underline{v}_1, \underline{r}, t)$ is known as the *correlation function*. In the derivation of the Boltzmann collision integral we have neglected the correlation effects between the particles and we have taken this joint probability as being proportional to $f_{\alpha}(\underline{r}, \underline{v}, t) f_{\beta}(\underline{r}, \underline{v}_1, t)$. The *irreversible* character of the Boltzmann equation, to be discussed in the next section, is a consequence of the molecular chaos assumption. In order to avoid this approximation the only alternative is to work with the reversible equations of the BBGKY (Bogoliubov, Born, Green, Kirkwood and Yvon) hierarchy. This treatment, however, is beyond the scope of this text.

For gaseous systems in which the characteristic interaction length is much less than the average interparticle distance, and where temporal and spatial gradients are not very large, the Boltzmann equation is nevertheless very well verified experimentally and, in this respect, constitutes one of the basic relations of the kinetic theory of gases.

2.4 - Rate of change of a physical quantity as a result of collisions

In section 2, of Chapter 8, we have represented the time rate of change of a physical quantity $\chi(\underline{y})$ per unit volume, for the particles of type α , due to collisions with the other particles in the plasma, by

$$\left[\frac{\delta}{\delta t} (n_\alpha \langle \chi \rangle_\alpha) \right]_{\text{coll}} = \int_{\mathbf{v}} \chi \left(\frac{\delta f_\alpha}{\delta t} \right)_{\text{coll}} d^3\mathbf{v} \quad (2.25)$$

Using the Boltzmann collision integral,

$$\left(\frac{\delta f_\alpha}{\delta t} \right)_{\text{coll}} = \sum_{\beta} \int_{\Omega} \int_{\mathbf{v}_1} (f'_\alpha f'_{\beta 1} - f_\alpha f_{\beta 1}) g \sigma(\Omega) d\Omega d^3\mathbf{v}_1 \quad (2.26)$$

we obtain the following expression for (2.25),

$$\left[\frac{\delta}{\delta t} (n_\alpha \langle \chi \rangle_\alpha) \right]_{\text{coll}} = \sum_{\beta} \int_{\Omega} \int_{v_1} \int_v (f'_\alpha f'_{\beta_1} - f_\alpha f_{\beta_1}) \chi g \sigma(\Omega) d\Omega d^3v_1 d^3v \quad (2.27)$$

Recall that for each direct collision there is a corresponding inverse collision with the same cross section. Hence, the integrals over \underline{v} and \underline{v}_1 can be replaced by integrals over \underline{v}' and \underline{v}'_1 , respectively, without altering the result. Therefore, the first group of integrals in (2.27) may be written as

$$\sum_{\beta} \int_{\Omega} \int_{v_1} \int_v f'_\alpha f'_{\beta_1} \chi g \sigma(\Omega) d\Omega d^3v_1 d^3v = \sum_{\beta} \int_{\Omega} \int_{v_1} \int_v f_\alpha f_{\beta_1} \chi' g \sigma(\Omega) d\Omega d^3v_1 d^3v \quad (2.28)$$

where we have replaced $d^3v' d^3v'_1$ by $d^3v d^3v_1$. Using this expression, results in the following alternative form for the collision term in (2.27),

$$\left[\frac{\delta}{\delta t} (n_\alpha \langle \chi \rangle_\alpha) \right]_{\text{coll}} = \sum_{\beta} \int_{\Omega} \int_{v_1} \int_v f_\alpha f_{\beta_1} (\chi' - \chi) g \sigma(\Omega) d\Omega d^3v_1 d^3v \quad (2.29)$$

Note that the property $X(\underline{v})$ is associated with the particles of type α and that X' denotes $X(\underline{v}')$. Note also that only the quantity X' on the right-hand side of (2.29) is a function of the *after* collision velocity \underline{v}' .

The result just derived applies to the special case of binary collisions in a dilute plasma (or gas), when processes of creation and disappearance of particles, as well as radiation losses are unimportant.

3. THE BOLTZMANN'S H FUNCTION

An important characteristic of the Boltzmann collision term is that it drives the distribution function towards the equilibrium state in an *irreversible* way. This irreversible character of the Boltzmann collision term, as mentioned before, is a consequence of the molecular chaos assumption, which neglects the correlation effects between the particles.

In order to place in evidence this aspect of the Boltzmann collision term, we introduce now the Boltzmann's function $H(t)$. For simplicity, we will consider the particles to be uniformly distributed in space (having no density gradients) and isolated from external forces. The distribution function is therefore independent of \underline{r} and can be denoted $f(\underline{v}, t)$. We define, according to Boltzmann, the function $H(t)$ by

$$H(t) = \int_{\underline{v}} f(\underline{v}, t) \ln f(\underline{v}, t) d^3v \quad (3.1)$$

For problems involving spatial gradients the function $H(t)$, defined in (3.1), is $H_{\text{total}}(t)$ per unit volume, where

$$H_{\text{total}}(t) = \int_r \int_v f(\underline{r}, \underline{v}, t) \ln f(\underline{r}, \underline{v}, t) d^3v d^3r \quad (3.2)$$

The function $H(t)$ is proportional to the *entropy* per unit volume of the system according to

$$\frac{S}{V} = -kH \quad (3.3)$$

where S denotes the total entropy, V is the volume of the system and k is Boltzmann's constant. More generally, for systems in which spatial gradients are present we have

$$S = -kH_{\text{total}} \quad (3.4)$$

with H_{total} as defined in (3.2).

3.1 - Boltzmann's H theorem

The Boltzmann's H theorem states that if $f(\underline{v}, t)$ satisfies the Boltzmann equation, that is, if

$$\frac{\partial f(\underline{v}, t)}{\partial t} = \int_{\Omega} \int_{\underline{v}_1} [f(\underline{v}', t) f(\underline{v}'_1, t) - f(\underline{v}, t) f(\underline{v}_1, t)] g \sigma(\Omega) d\Omega d^3v_1 \quad (3.5)$$

then

$$\frac{\partial H(t)}{\partial t} \leq 0 \quad (3.6)$$

To prove this theorem let us take the derivate of (3.1) with respect to time, which gives

$$\frac{\partial H}{\partial t} = \int_{\underline{v}} (1 + \ln f) \frac{\partial f}{\partial t} d^3v \quad (3.7)$$

Substituting (3.5) into (3.7) gives

$$\frac{\partial H}{\partial t} = \int_{\Omega} \int_{\underline{v}} \int_{\underline{v}_1} (1 + \ln f) (f' f'_1 - f f_1) g \sigma(\Omega) d\Omega d^3v_1 d^3v \quad (3.8)$$

where the notation $f'_1 = f(\underline{v}'_1, t)$, and so on, has been used. The variables of integration \underline{v} and \underline{v}_1 are dummy variables, and can be interchanged in the integrand of (3.8) without changing the value of the integral, since $\sigma(\Omega)$ and $g = |\underline{v}_1 - \underline{v}|$ are also invariants. Thus, (3.8) can be written as

$$\frac{\partial H}{\partial t} = \int_{\Omega} \int_{\underline{v}_1} \int_{\underline{v}} (1 + \ln f_1) (f'_1 f' - f_1 f) g \sigma(\Omega) d\Omega d^3v d^3v_1 \quad (3.9)$$

Adding Eqs. (3.8) and (3.9), and dividing by 2, gives

$$\frac{\partial H}{\partial t} = \frac{1}{2} \int_{\Omega} \int_{\underline{v}} \int_{\underline{v}_1} [2 + \ln (f f_1)] (f' f'_1 - f f_1) g \sigma(\Omega) d\Omega d^3v_1 d^3v \quad (3.10)$$

In this equation we can replace the velocities *before* collision, \underline{v} and \underline{v}_1 , by the velocities *after* collision, \underline{v}' and \underline{v}'_1 , respectively, without altering the value of the integral, since for each collision there exists an inverse collision with the same differential cross section $\sigma(\Omega)$. We have already seen that $d^3v' d^3v'_1 = d^3v d^3v_1$ and $g = g'$.

Consequently, (3.10) may be written as

$$\frac{\partial H}{\partial t} = \frac{1}{2} \int_{\Omega} \int_{\underline{v}} \int_{\underline{v}_1} [2 + \ln(f' f'_1)] (f f_1 - f' f'_1) g \sigma(\Omega) d\Omega d^3v_1 d^3v \quad (3.11)$$

We now combine Eqs. (3.10) and (3.11) to obtain

$$\frac{\partial H}{\partial t} = \frac{1}{4} \int_{\Omega} \int_{\mathbf{v}} \int_{\mathbf{v}_1} \left[\ln \left(\frac{f f_1}{f' f'_1} \right) \right] (f' f'_1 - f f_1) g \sigma(\Omega) d\Omega d^3\mathbf{v}_1 d^3\mathbf{v} \quad (3.12)$$

In this expression it is clear that if $f' f'_1 > f f_1$ then $\ln(f f_1 / f' f'_1) < 0$, and consequently $\partial H / \partial t < 0$, since all other factors appearing in the right-hand side of (3.12) are positive. On the other hand, if $f' f'_1 < f f_1$ then $\ln(f f_1 / f' f'_1) > 0$ and, again, $\partial H / \partial t < 0$. When $f' f'_1 = f f_1$, both factors are zero and $\partial H / \partial t = 0$.

This proves the H theorem and shows that, when f satisfies the Boltzmann equation, the functional $H(t)$ always decreases monotonically with time until it reaches a limiting value, which occurs when there is no further change with time in the system. This limiting value is reached *only* when

$$f' f'_1 = f f_1 \quad (3.13)$$

so that this condition is *necessary* for $\partial H / \partial t = 0$ and, consequently, it is also a necessary condition for the equilibrium state. According to the Boltzmann equation (3.5), the *equilibrium* distribution function satisfies the following integral equation

$$\int_{\Omega} \int_{\mathbf{v}_1} \left[f(\underline{\mathbf{v}}') f(\underline{\mathbf{v}}'_1) - f(\underline{\mathbf{v}}) f(\underline{\mathbf{v}}_1) \right] g \sigma(\Omega) d\Omega d^3\mathbf{v}_1 = 0 \quad (3.14)$$

so that the condition (3.13) is also a *sufficient* condition for the equilibrium state.

It is instructive to note that Eq. (3.13) can be considered as an example of the *general principle of detailed balance* of statistical mechanics, as discussed in section 1, of Chapter 7, where it was used to derive the Maxwell-Boltzmann equilibrium distribution function. An important conclusion that can be drawn from (3.13) is that the equilibrium distribution function is independent of the differential collision cross section, $\sigma(\Omega)$, considered to be nonzero. The Maxwell-Boltzmann distribution function is therefore the only distribution for the equilibrium state that can exist in a uniform gas in the absence of external forces.

3.2 - Analysis of Boltzmann's H theorem

According to (3.3), the H theorem states that the entropy of a given isolated system always increases with time until it reaches the equilibrium state.

Although this *irreversible* behavior is compatible with the laws of thermodynamics it is, nevertheless, in disagreement with the laws of mechanics, which are *reversible*. If, at a given instant of time, the velocities of all the particles in the system were reversed, the laws of mechanics predict that each particle would describe, in the opposite sense, its previous trajectory. However, we have seen that the Boltzmann collision term leads to a irreversible temporal evolution of

the distribution function and of the function H . The existence of this paradox has its origin in the molecular chaos assumption that was used in the derivation of the Boltzmann collision term.

Recall that the molecular chaos assumption admits that, if $f(\underline{r}, \underline{v}, t)$ is proportional to the probability of finding in a given volume element d^3r about \underline{r} a particle with velocity \underline{v} , at the instant t , then the joint probability of simultaneously finding in the same volume element d^3r about \underline{r} a particle with velocity \underline{v} and another particle with velocity \underline{v}_1 , at the instant t , is proportional to the product $f(\underline{r}, \underline{v}, t) f(\underline{r}, \underline{v}_1, t)$. Thus, it neglects any possible correlation that may exist between the particles. Generally, the state of the gas may or may not satisfy the molecular chaos assumption and, consequently, the distribution function describing the gas may or may not satisfy the Boltzmann equation. The distribution function, which characterizes the state of the gas, will obey the Boltzmann equation only at the instants of time when the molecular chaos assumption holds true for the gas. The H theorem, therefore, is also valid only when this condition is satisfied.

We shall show now that at the instants of time when the state of the gas satisfies the molecular chaos assumption, the function $H(t)$ is at a local maximum. For this purpose consider a gas not in equilibrium, which is in the state of molecular chaos at the instant $t = t_0$. The H theorem implies, therefore, that at the instant $t_0 + dt$ we have $dH/dt \leq 0$. Consider a second gas which at the instant $t = t_0$ is exactly identical to the first one, except

that the velocities of all the particles have directions opposite to the velocities of the first one, has the same function $H(t)$ as the first one, and is in a state of molecular chaos at $t = t_0$. Consequently, at the instant $t_0 + dt$ we must have $dH/dt \leq 0$, according to the H theorem. On the other hand, due to the invariance of the equations of motion under time reversal, the time evolution of the second gas corresponds to the past of the first. This means that for the first gas we must have

$$\frac{dH(t)}{dt} \leq 0 \quad \text{at} \quad t = t_0 + dt \quad (3.15a)$$

$$\frac{dH(t)}{dt} \geq 0 \quad \text{at} \quad t = t_0 - dt \quad (3.15b)$$

which shows that at the instant when the condition of molecular chaos is satisfied, the function $H(t)$ is at a local maximum. This is illustrated in Fig. 2 at the instant $t = t_0$ indicated by the number (2). At the instants when $H(t)$ does not present a local maximum, as for example at the instants indicated by the numbers (1) and (3) in Fig. 2, the gas is not in a state of molecular chaos. Note that dH/dt need not, necessarily, be a continuous function of time and may change abruptly as a result of collisions.

The time evolution of $H(t)$ is governed by the collisional interactions between the particles, which occur at random, and which can establish, as well as destroy the state of molecular

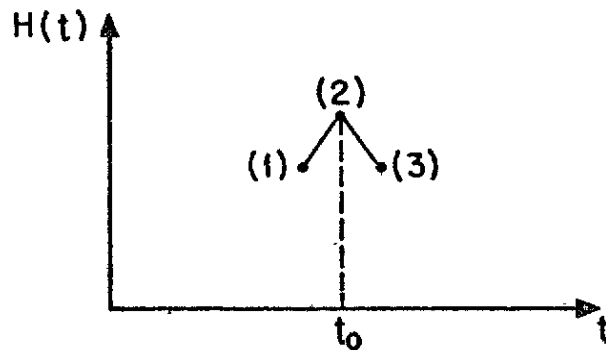

Fig. 2 - When the gas satisfies the condition of molecular chaos, the function $H(t)$ is at a local maximum, indicated here by the point denoted (2).

chaos as time passes. Fig. 3 illustrates how $H(t)$ may vary with time. Some of the instants when the condition of molecular chaos is satisfied are indicated by dots in the curve of $H(t)$. If the condition of molecular chaos prevails during most of the time, as in a dilute gas, for example, $H(t)$ will be at a local maximum most of the time. Due to the random character of the sequence of collisions, these instants of molecular chaos will probably be distributed in time in a almost uniform way. On the other hand, the time variation of $H(t)$ obtained using the distribution function that satisfies the Boltzmann equation is represented by a smooth curve of negative slope which tries to fit, with a minimum deviation, all the points (instants) of the real curve of $H(t)$ in which the condition of molecular chaos is satisfied, as shown by the dashed line in Fig. 3. The state of molecular chaos can therefore be considered as a convenient mathematical model to describe a state not in equilibrium.

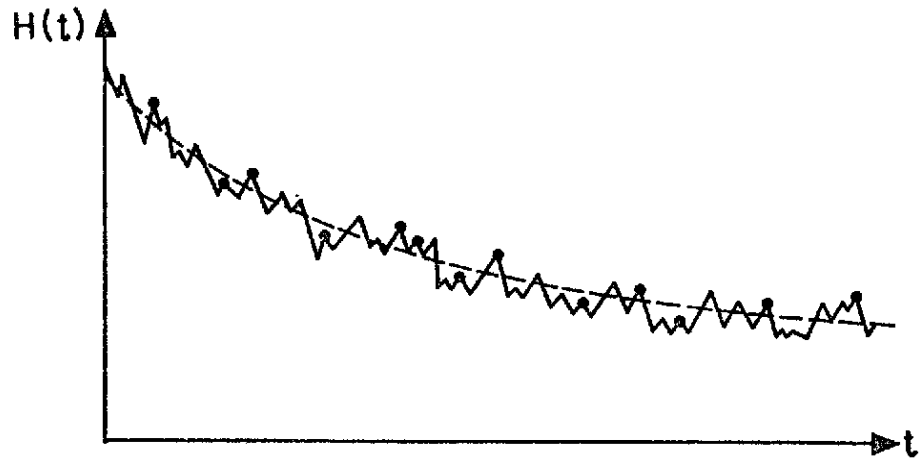

Fig. 3 - The time evolution of $H(t)$ for a gas initially not in an equilibrium state is indicated by the solid curve. The dashed curve is the time variation of $H(t)$ predicted by the Boltzmann equation. The dots indicate some of the instants when the condition of molecular chaos is satisfied.

The Boltzmann equation, although strictly valid only at the instants when the gas is in the state of molecular chaos, can, nevertheless, be considered generally valid in a *statistical* sense at any instant. Similarly, the H theorem is also valid only in a statistical sense.

3.3 - Maximum entropy or minimum H approach for deriving the equilibrium distribution function

The Maxwell-Boltzmann equilibrium distribution function can also be derived by performing a variational calculation on the function $H(t)$. We have seen that at equilibrium H is a minimum, so that for a one-component uniform gas we must have at *equilibrium*

$$\delta H = \delta \int_{\mathbf{v}} f \ln f d^3\mathbf{v} = 0 \quad (3.16)$$

The symbol δ , before a given quantity, denotes a variation in that quantity as a result of a small change in the distribution function f . Carrying out the variation indicated in Eq. (3.16) in a formal way, we have

$$\delta H = \int_{\mathbf{v}} (1 + \ln f) \delta f d^3\mathbf{v} = 0 \quad (3.17)$$

There are, however, certain macroscopic constraints imposed on the system. When we vary f slightly, we cannot violate the conservation of mass, momentum and energy for the system as a whole. Therefore, the variational integral (3.17) is subjected to the constraints that the total mass, momentum and energy densities of the uniform gas remain constant under the variation δf . The constancy of the mass density under a small change δf in f , requires that

$$\delta(\rho) = m \int_{\mathbf{v}} \delta f d^3\mathbf{v} = 0 \quad (3.18)$$

Similarly, for the constancy of the momentum density,

$$\delta(\rho \langle \underline{\mathbf{v}} \rangle) = m \int_{\mathbf{v}} \underline{\mathbf{v}} \delta f d^3\mathbf{v} = 0 \quad (3.19)$$

and for the energy density,

$$\delta\left(\frac{1}{2} \rho \langle v^2 \rangle\right) = \frac{1}{2} m \int_{\mathbf{v}} v^2 \delta f d^3v = 0 \quad (3.20)$$

We can now solve the variational integral in (3.17) subject to the constraints expressed in Eqs. (3.18), (3.19) and (3.20) by the method of the *Lagrange multipliers*. Multiplying Eq. (3.18) by the Lagrange multiplier a_1 , the i 'th component of Eq. (3.19) by the Lagrange multiplier a_{2i} (for $i = x, y, z$), Eq. (3.20) by the Lagrange multiplier a_3 , and adding the resulting equations together with (3.17), gives

$$m \int_{\mathbf{v}} \left(1 + \ln f + a_1 + \underline{a}_2 \cdot \underline{v} + \frac{1}{2} a_3 v^2\right) \delta f d^3v = 0 \quad (3.21)$$

where we used the notation $\underline{a}_2 \cdot \underline{v} = a_{2x} v_x + a_{2y} v_y + a_{2z} v_z$. The variation δf is now completely *arbitrary*, since all the constraints imposed on the system have been taken into account in Eq. (3.21). Thus, this integral can be equal to zero if and only if

$$\ln f = - \left(1 + a_1 + \underline{a}_2 \cdot \underline{v} + \frac{1}{2} a_3 v^2\right) \quad (3.22)$$

The form of this equation is identical to Eq. (7.1.19), which we solved in Chapter 7 to obtain the Maxwell-Boltzmann distribution function. Hence it leads, in identical fashion, to the equilibrium distribution function

$$f = n \left(\frac{m}{2\pi kT} \right)^{3/2} \exp \left[- m(\underline{v} - \underline{u})^2 / 2kT \right] \quad (3.23)$$

with $\underline{v} - \underline{u} = \underline{c}$. The Maxwellian distribution function, besides being the *equilibrium* solution of the Boltzmann equation is, therefore, also the *most probable* distribution consistent with the specified macroscopic parameters n , \underline{u} and T of the system.

3.4 - Mixture of various species of particles

For the case of a mixture containing different species of particles, *each* species having a given number density n_α , average velocity \underline{u}_α , and temperature T_α , we can still perform a variational calculation to determine the *most probable* distribution subject to the constraints provided by the set of macroscopic parameters n_α , \underline{u}_α , T_α , for each species of particles. Note that this is *not* an equilibrium situation, unless the temperatures and mean velocities of all species are equal. To determine the most probable distribution function for this nonequilibrium gas mixture (*each* species having their *own* number density, mean velocity and temperature), we independently minimize each H_α ,

$$H_\alpha = \int_{\underline{v}} f_\alpha \ln f_\alpha d^3v \quad (3.24)$$

This also minimizes H for the mixture, since

$$H = \sum_{\alpha} H_{\alpha} \tag{3.25}$$

For the species of type α , when H_{α} is at its minimum, we must have $\delta H_{\alpha} = 0$ for a small variation δf_{α} in f_{α} . The macroscopic parameters n_{α} , u_{α} and T_{α} must all remain fixed when f_{α} is varied. The problem is completely analogous to the one we solved in the previous subsection for a one-component gas, and leads, in identical fashion, to Eq. (3.23) for each species. Therefore, each particle species has a Maxwellian distribution function, but with its own number density, mean velocity and temperature. Although this is not an equilibrium situation for the whole gas (unless the mean velocities and temperatures of all species are the same), it is, nevertheless, the most probable distribution function for this system subject to the specified constraints.

4. BOLTZMANN COLLISION TERM FOR A WEAKLY IONIZED PLASMA

In this section we derive from the Boltzmann equation an approximate expression for the collision term for a weakly ionized plasma in which only the collisions between electrons and neutral particles are important. The distribution function for the neutral particles is assumed to be homogeneous and isotropic. The external forces acting on the electrons are assumed to be small, so that the electrons are not very far from the equilibrium state. Consequently, the spatial inhomogeneity

and the anisotropy of the nonequilibrium distribution function for the electrons are very small, since the nonequilibrium state is only slight perturbed from the equilibrium state. In the equilibrium state the electrons are assumed to have no drift velocity and their distribution function is isotropic and homogeneous.

4.1 - Spherical harmonic expansion of the distribution function

Let (v, θ, ϕ) denote spherical coordinates in velocity space, as shown in Fig. 4. Since the anisotropy of the nonequilibrium distribution function is very small, the dependence of $f(\underline{r}, \underline{v}, t)$ on θ and ϕ is very weak. Hence, it is appropriate to expand $f(\underline{r}, \underline{v}, t)$ in terms of the velocity space angular variables θ and ϕ , and retain only the first few terms of this expansion. Since ϕ varies between 0 and 2π , we can expand $f(\underline{r}, \underline{v}, t)$ in a Fourier series in ϕ . Furthermore, θ varies between 0 and π and, consequently, $\cos(\theta)$ varies between +1 and -1, which means that we can expand $f(\underline{r}, \underline{v}, t)$ in a series of Legendre polynomials in $\cos(\theta)$. Therefore, we can make a spherical harmonic expansion of the distribution function as follows

$$f(\underline{r}, \underline{v}, t) = \sum_{m=0}^{\infty} \sum_{n=0}^{\infty} P_n^m(\cos \theta) [f_{mn}(\underline{r}, v, t) \cos(m\phi) + g_{mn}(\underline{r}, v, t) \sin(m\phi)] \quad (4.1)$$

where the functions $P_n^m(\cos \theta)$ represent the associated Legendre polynomials, and the functions f_{mn} and g_{mn} can be considered as coefficients of the expansion.

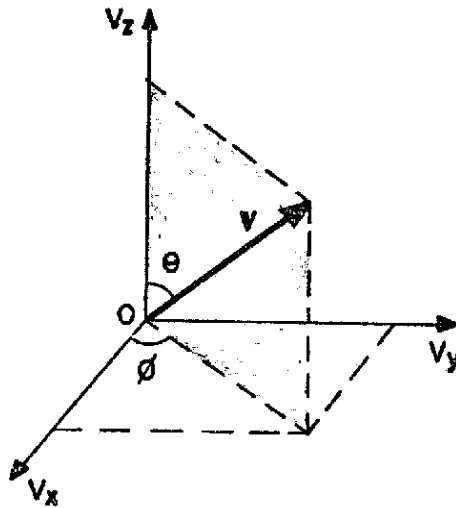

Fig. 4 - Spherical coordinates (v, θ, ϕ) in velocity space.

The first term in the expansion (4.1) corresponds to $m = 0$, $n = 0$, and since $P_0^0(\cos \theta) = 1$, it follows that it is given by $f_{00}(\underline{r}, v, t)$. This leading term is the isotropic distribution function corresponding to the equilibrium state of the electrons. The term corresponding to $m = 1$, $n = 0$, vanishes, since $P_0^1(\cos \theta) = 0$. The next highest order term in (4.1) corresponds to $m = 0$, $n = 1$, and since $P_1^0(\cos \theta) = \cos \theta$, it is given by $f_{01}(\underline{r}, v, t) \cos \theta$. Therefore, retaining only the first two non-zero terms of the spherical harmonic expansion (4.1), in view of the fact that the anisotropy is assumed to be small, we obtain

$$f(\underline{r}, \underline{v}, t) = f_{00}(\underline{r}, v, t) + \frac{\underline{v} \cdot \underline{\hat{v}}_z}{v} f_{01}(\underline{r}, v, t) \quad (4.2)$$

where we have replaced $\cos \theta$ by $\underline{v} \cdot \underline{\hat{v}}_z/v$ (see Fig. 4). The second term in the right-hand side of (4.2) corresponds to the small anisotropy due to the spatial inhomogeneity and the external forces on the electrons.

4.2 - Approximate expression for the Boltzmann collision term

The Boltzmann collision integral, given in Eq. (2.12), can be written for the case of binary electron-neutral collisions as

$$\left(\frac{\delta f_e}{\delta t}\right)_{\text{coll}} = \int \int \int_{b \in v_1} (f'_e f'_{n_1} - f_e f_{n_1}) g b db d\epsilon d^3v_1 \quad (4.3)$$

where we have replaced $\sigma(\Omega) d\Omega$ by $b db d\epsilon$. Here f_e represents the nonequilibrium distribution function for the electrons, and f_n is the isotropic equilibrium distribution function for the neutral particles.

In a first approximation we may assume the neutral particles to be stationary and not affected by collisions with electrons, since the mass of a neutral particle is much larger than that of an electron. Hence, we assume that

$$\underline{v}_1 = \underline{v}'_1 \cong 0 \quad (4.4)$$

$$f_{n1} = f'_{n1} \quad (4.5)$$

Therefore, (4.3) becomes

$$\left(\frac{\delta f_e}{\delta t}\right)_{\text{coll}} = \int_{v_1} f_n d^3v_1 \int_0^{2\pi} d\varepsilon \int_0^\infty (f'_e - f_e) g b db \quad (4.6)$$

Since the number density of the neutral particles is given by

$$n_n = \int_{v_1} f_n d^3v_1 \quad (4.7)$$

we can write (4.6) as

$$\left(\frac{\delta f_e}{\delta t}\right)_{\text{coll}} = n_n \int_0^{2\pi} d\varepsilon \int_0^\infty (f'_e - f_e) g b db \quad (4.8)$$

Further, from (4.2), the distribution function for the electrons, *before collision*, is given by

$$f_e \equiv f_e(\underline{r}, \underline{v}, t) = f_{00}(\underline{r}, \underline{v}, t) + \frac{\underline{v} \cdot \hat{\underline{v}}_z}{v} f_{01}(\underline{r}, \underline{v}, t) \quad (4.9)$$

and, *after collision*, by

$$\begin{aligned}
 f'_e \equiv f_e(\underline{r}, \underline{v}', t) &= f_{00}(\underline{r}, v', t) + \frac{\underline{v}' \cdot \hat{\underline{v}}_z}{v'} f_{01}(\underline{r}, v', t) \\
 &= f_{00}(\underline{r}, v, t) + \frac{\underline{v}' \cdot \hat{\underline{v}}_z}{v} f_{01}(\underline{r}, v, t) \quad (4.10)
 \end{aligned}$$

In this last equation we have considered $v' = v$, in view of the fact that the electrons do not lose energy on collisions, since the neutrals are much more massive and considered at rest in a first approximation. This means that $\underline{v} = \underline{g}$ and $\underline{v}' = \underline{g}'$ [see Eq.(4.4)], and since $g = g'$ [see Eq. (20.2.16)] we have $v = v'$. Note, however, that $\underline{v} \neq \underline{v}'$. Therefore, from (4.9) and (4.10), we have

$$f'_e - f_e = \frac{(\underline{v}' - \underline{v}) \cdot \hat{\underline{v}}_z}{v} f_{01}(\underline{r}, v, t) \quad (4.11)$$

Without any loss of generality we can choose the v_z - axis as being parallel to the initial relative velocity, \underline{g} , of the electron. Therefore,

$$\begin{aligned}
 (\underline{v}' - \underline{v}) \cdot \hat{\underline{v}}_z &= \underline{g}' \cdot \hat{\underline{v}}_z - \underline{g} \cdot \hat{\underline{v}}_z \\
 &= g \cos \chi - g \\
 &= v (\cos \chi - 1) \quad (4.12)
 \end{aligned}$$

where χ denotes the scattering angle, that is, the angle between \underline{g} and \underline{g}' (see Fig. 3, of Chapter 20). Substituting (4.12) into (4.11), we obtain

$$f'_e - f_e = - (1 - \cos \chi) f_{01}(\underline{r}, v, t) \quad (4.13)$$

The substitution of (4.13) into (4.8), yields

$$\left(\frac{\delta f_e}{\delta t}\right)_{\text{coll}} = - n_n g f_{01}(\underline{r}, v, t) \int_0^{2\pi} d\epsilon \int_0^\infty (1 - \cos \chi) b db \quad (4.14)$$

Since the momentum transfer cross section, σ_m , for collisions between electrons and neutral particles, is defined by [(see Eq.(20.5.10)]

$$\begin{aligned} \sigma_m &= \int_{\Omega} (1 - \cos \chi) \sigma(\Omega) d\Omega \\ &= \int_0^{2\pi} d\epsilon \int_0^\infty (1 - \cos \chi) b db \end{aligned} \quad (4.15)$$

we can write (4.14) as

$$\left(\frac{\delta f_e}{\delta t}\right)_{\text{coll}} = - n_n g \sigma_m f_{01}(\underline{r}, v, t) \quad (4.16)$$

If we substitute $f_{01}(\underline{r}, \underline{v}, t)$ in (4.16) using (4.9), and noting that $\underline{v} \cdot \underline{\hat{v}}_Z/v = \underline{g} \cdot \underline{\hat{v}}_Z/g = 1$, we obtain

$$\begin{aligned} \left(\frac{\delta f_e}{\delta t} \right)_{\text{coll}} &= - n_n v \sigma_m (f_e - f_{oe}) \\ &= - \nu_r(v) (f_e - f_{oe}) \end{aligned} \quad (4.17)$$

where we have introduced the velocity-dependent relaxation collision frequency $\nu_r(v) = n_n v \sigma_m$, and where f_{00} , which characterizes the isotropic equilibrium state of the electrons, has been replaced by f_{oe} , in accordance with the notation used previously. Expression (4.17) is similar to the relaxation model (or Krook model) for the collision term introduced in section 6, of Chapter 5, except for the velocity-dependent collision frequency. Once the force of interaction between the electrons and the neutral particles has been specified, the momentum transfer cross section, σ_m , and consequently the relaxation collision frequency, $\nu_r(v)$, can be determined as functions of velocity.

4.3 - Rate of change of momentum due to collisions

The time rate of change of momentum per unit volume of the electron gas due to collisions with neutral particles is given, from (8.4.3), by

$$\underline{A}_e \equiv \left[\frac{\delta (\rho_e \underline{u}_e)}{\delta t} \right]_{\text{coll}} = m_e \int \underline{v} \left(\frac{\delta f_e}{\delta t} \right)_{\text{coll}} d^3v \quad (4.18)$$

Substituting (4.17) into (4.18), we obtain

$$\underline{A}_e = - m_e \int \nu_r(v) \underline{v} f_e d^3v + m_e \int \nu_r(v) \underline{v} f_{oe} d^3v \quad (4.19)$$

If we assume that the relaxation collision frequency, ν_r , does not depend on velocity, and if we consider that the electron gas has no drift velocity in the equilibrium state, that is,

$$\underline{u}_{oe} = \frac{1}{n_e} \int \underline{v} f_{oe} d^3v = 0 \quad (4.20)$$

then (4.19) becomes

$$\begin{aligned} \underline{A}_e &= - n_e m_e \nu_r \underline{u}_e \\ &= - \rho_e \nu_r \underline{u}_e \end{aligned} \quad (4.21)$$

where \underline{u}_e is the average velocity of the electrons in the nonequilibrium state. Eq. (4.21) corresponds to the expression used in the Langevin equation for the time rate of change of momentum per unit volume as a

result of collisions, in which a constant collision frequency, ν_c , was introduced phenomenologically.

5. THE FOKKER-PLANCK EQUATION

In this section we present a derivation of the Fokker-Planck equation, in which the collision term takes into account the simultaneous Coulomb interactions of a charged particle with the other charged particles in its Debye sphere. For this purpose we assume that the large-angle deflection of a charged particle, in a multiple Coulomb interaction, can be considered as a series of consecutive weak binary collisions (or grazing collisions), that is, as a succession of small-angle scatterings. Therefore, the Fokker-Planck collision term can be derived directly from the Boltzmann collision integral, which is valid for binary collisions, under the assumption that a series of consecutive weak (small-angle deflection) binary collisions is a good representation for the multiple Coulomb interaction. Only collisions between species of particles represented by the indices α and β will be considered.

5.1 - Derivation of the Fokker-Planck collision term

If $X(\underline{v})$ is some arbitrary function of velocity, associated with the particles of type α , then, according to Eqs. (2.27) and (2.29), the time rate of change of the quantity $X(\underline{v})$ per unit volume, as a result of collisions between particles of type α and those of type β , can be expressed as

$$\begin{aligned}
 \int_{\underline{v}} \chi(\underline{v}) \left(\frac{\delta f_{\alpha}}{\delta t} \right)_{\text{coll}} d^3v &= \int_{\Omega} \int_{\underline{v}_1} \int_{\underline{v}} (f'_{\alpha} f'_{\beta_1} - f_{\alpha} f_{\beta_1}) \chi g \sigma(\Omega) d\Omega d^3v_1 d^3v \\
 &= \int_{\Omega} \int_{\underline{v}_1} \int_{\underline{v}} f_{\alpha} f_{\beta_1} (\chi' - \chi) g \sigma(\Omega) d\Omega d^3v_1 d^3v
 \end{aligned} \tag{5.1}$$

where χ' denotes $\chi(\underline{v}')$. In this last expression only the quantity χ' is a function of the velocity after collision \underline{v}' . For weak binary collisions (or grazing collisions), we can write

$$\underline{v}' = \underline{v} + \Delta\underline{v} \tag{5.2}$$

where the change $\Delta\underline{v}$, due to collision, is assumed to be small. Since

$$\chi' \equiv \chi(\underline{v}') = \chi(\underline{v} + \Delta\underline{v}) \tag{5.3}$$

we can expand χ' in a Taylor series about the velocity \underline{v} , as

$$\chi(\underline{v} + \Delta\underline{v}) = \chi(\underline{v}) + \sum_i \frac{\partial \chi}{\partial v_i} \Delta v_i + \frac{1}{2} \sum_{i,j} \frac{\partial^2 \chi}{\partial v_i \partial v_j} \Delta v_i \Delta v_j + \dots \tag{5.4}$$

Substituting (5.4) into (5.1), and neglecting higher order terms, we obtain

$$\int_{\underline{v}} \chi \left(\frac{\delta f_{\alpha}}{\delta t} \right)_{\text{coll}} d^3v = \int_{\Omega} \int_{\underline{v}_1} \int_{\underline{v}} f_{\alpha} f_{\beta_1} \left(\sum_i \frac{\partial \chi}{\partial v_i} \Delta v_i + \right. \\ \left. + \frac{1}{2} \sum_{i,j} \frac{\partial^2 \chi}{\partial v_i \partial v_j} \Delta v_i \Delta v_j \right) g \sigma(\Omega) d\Omega d^3v_1 d^3v \quad (5.5)$$

The next step is to factor out the arbitrary function $\chi(\underline{v})$ from Eq. (5.5). This can be accomplished by integrating the first group of integrals involving $\partial \chi / \partial v_i$, in (5.5), by parts once, and the second group of integrals involving $\partial^2 \chi / (\partial v_i \partial v_j)$ by parts twice. For example, for the x component of the first group of integrals involving $\partial \chi / \partial v_i$, we have

$$\int_{\Omega} \int_{\underline{v}_1} \int_{\underline{v}} \frac{\partial \chi(\underline{v})}{\partial v_x} \Delta v_x f_{\alpha}(\underline{v}) f_{\beta}(\underline{v}_1) g \sigma(\Omega) d\Omega d^3v_1 d^3v = \\ = \int_{\Omega} \int_{\underline{v}_1} \left[\int_{\underline{v}} dv_y dv_z \frac{\partial \chi(\underline{v})}{\partial v_x} dv_x (v'_x - v_x) f_{\alpha}(\underline{v}) g \sigma(\Omega) d\Omega \right] f_{\beta}(\underline{v}_1) d^3v_1 \quad (5.6)$$

For the term within brackets we can take

$$dV = \frac{\partial \chi(\underline{v})}{\partial v_x} dv_x \quad (5.7)$$

$$U = (v'_x - v_x) f_\alpha(\underline{v}) g \sigma(\Omega) d\Omega \quad (5.8)$$

and perform the integral over v_x by parts to obtain

$$\begin{aligned} & \int_{v_x} \frac{\partial \chi(\underline{v})}{\partial v_x} dv_x (v'_x - v_x) f_\alpha(\underline{v}) g \sigma(\Omega) d\Omega = \\ & = - \int_{v_x} \chi(\underline{v}) \frac{\partial}{\partial v_x} \left[(v'_x - v_x) f_\alpha(\underline{v}) g \sigma(\Omega) d\Omega \right] dv_x \end{aligned} \quad (5.9)$$

where the integrated term vanishes since f must be zero at $\pm \infty$.

Therefore, we find for the integral in (5.6)

$$\begin{aligned} & \int_{\Omega} \int_{v_1} \int_v \frac{\partial \chi(\underline{v})}{\partial v_x} \Delta v_x f_\alpha(\underline{v}) f_\beta(\underline{v}_1) g \sigma(\Omega) d\Omega d^3v_1 d^3v = \\ & = \int_{\Omega} \int_{v_1} \int_v - \chi(\underline{v}) \frac{\partial}{\partial v_x} \left[\Delta v_x f_\alpha(\underline{v}) g \sigma(\Omega) d\Omega \right] f_\beta(\underline{v}_1) d^3v_1 d^3v \end{aligned} \quad (5.10)$$

Performing the other integrals in (5.5) by parts, in a similar way, yields for the collision term

$$\begin{aligned}
 \int_{\mathbf{v}} \chi \left(\frac{\delta f_{\alpha}}{\delta t} \right)_{\text{coll}} d^3\mathbf{v} &= \int_{\Omega} \int_{\mathbf{v}_1} \int_{\mathbf{v}} - \chi \sum_i \frac{\partial}{\partial v_i} \left[\Delta v_i f_{\alpha} g \sigma(\Omega) d\Omega \right] f_{\beta_1} d^3\mathbf{v}_1 d^3\mathbf{v} + \\
 &+ \int_{\Omega} \int_{\mathbf{v}_1} \int_{\mathbf{v}} \frac{1}{2} \chi \sum_{i,j} \frac{\partial^2}{\partial v_i \partial v_j} \left[\Delta v_i \Delta v_j f_{\alpha} g \sigma(\Omega) d\Omega \right] f_{\beta_1} d^3\mathbf{v}_1 d^3\mathbf{v} \\
 &= \int_{\mathbf{v}} \chi \left[- \sum_i \frac{\partial}{\partial v_i} (f_{\alpha} \int_{\Omega} \int_{\mathbf{v}_1} \Delta v_i g \sigma(\Omega) d\Omega f_{\beta_1} d^3\mathbf{v}_1) \right] d^3\mathbf{v} + \\
 &+ \int_{\mathbf{v}} \chi \left[\frac{1}{2} \sum_{i,j} \frac{\partial^2}{\partial v_i \partial v_j} (f_{\alpha} \int_{\Omega} \int_{\mathbf{v}_1} \Delta v_i \Delta v_j g \sigma(\Omega) d\Omega f_{\beta_1} d^3\mathbf{v}_1) \right] d^3\mathbf{v}
 \end{aligned} \tag{5.11}$$

We now define the quantities

$$\langle \Delta v_i \rangle_{\text{av}} = \int_{\Omega} \int_{\mathbf{v}_1} \Delta v_i g \sigma(\Omega) d\Omega f_{\beta_1} d^3\mathbf{v}_1 \tag{5.12}$$

and

$$\langle \Delta v_i \Delta v_j \rangle_{av} = \int_{\Omega} \int_{v_1} \Delta v_i \Delta v_j g \sigma(\Omega) d\Omega f_{\beta_1} d^3v_1 \quad (5.13)$$

which are modified averages over the scattering angle and the velocity distribution of the scatterers. Using this notation (5.11) becomes

$$\int_v \chi \left(\frac{\delta f_\alpha}{\delta t} \right)_{coll} d^3v = \int_v \chi \left[- \sum_i \frac{\partial}{\partial v_i} (f_\alpha \langle \Delta v_i \rangle_{av}) + \right. \\ \left. + \frac{1}{2} \sum_{i,j} \frac{\partial^2}{\partial v_i \partial v_j} (f_\alpha \langle \Delta v_i \Delta v_j \rangle_{av}) \right] d^3v \quad (5.14)$$

Since this equation must hold for any arbitrary function of velocity $\chi(\underline{v})$, it follows that we must have (taking $\chi = 1$)

$$\left(\frac{\delta f_\alpha}{\delta t} \right)_{coll} = - \sum_i \frac{\partial}{\partial v_i} (f_\alpha \langle \Delta v_i \rangle_{av}) + \\ + \frac{1}{2} \sum_{i,j} \frac{\partial^2}{\partial v_i \partial v_j} (f_\alpha \langle \Delta v_i \Delta v_j \rangle_{av}) \quad (5.15)$$

This is the *Fokker-Planck collision term* and the quantities $\langle \Delta v_i \rangle_{av}$ and $\langle \Delta v_i \Delta v_j \rangle_{av}$ are known, respectively, as the Fokker-Planck coefficients of *dynamical friction* and of *diffusion in velocity space*. They give the mean rate at which Δv_i and $\Delta v_i \Delta v_j$, respectively, are changed due to many consecutive weak Coulomb collisions.

Note that the Fokker-Planck collision term (5.15) has terms of opposite sign, which may result in no net change in f_α as a result of collisions. A dimensional analysis of Eq. (5.12) shows that the Fokker-Planck coefficient $\langle \Delta v_i \rangle_{av}$ has dimensions of force per unit mass, and tends to accelerate or decelerate the particles until they reach the average equilibrium velocity. This process is called dynamical friction. On the other hand, the Fokker-Planck coefficient $\langle \Delta v_i \Delta v_j \rangle_{av}$ represents diffusion in velocity space, and tends to spread the representative points in velocity space until equilibrium is reached. Under equilibrium conditions, diffusion in velocity space is balanced by dynamical friction, and there is no net change in f_α as a result of collisions, so that $(\delta f_\alpha / \delta t)_{coll} = 0$. This process is illustrated schematically in Fig. 5.

In principle, the expansion procedure used to obtain the Fokker-Planck collision term can be extended to any number of terms. However, in practice only the first two terms of the expansion, shown in (5.15), are ever used, so that Eq. (5.15) can be considered as a reasonable approximation to the collision term $(\delta f_\alpha / \delta t)_{coll}$ when

$\Delta \underline{v} = \underline{v}' - \underline{v}$ is small for most collisions. This is generally supposed to be the case for long-range forces such as the Coulomb force.

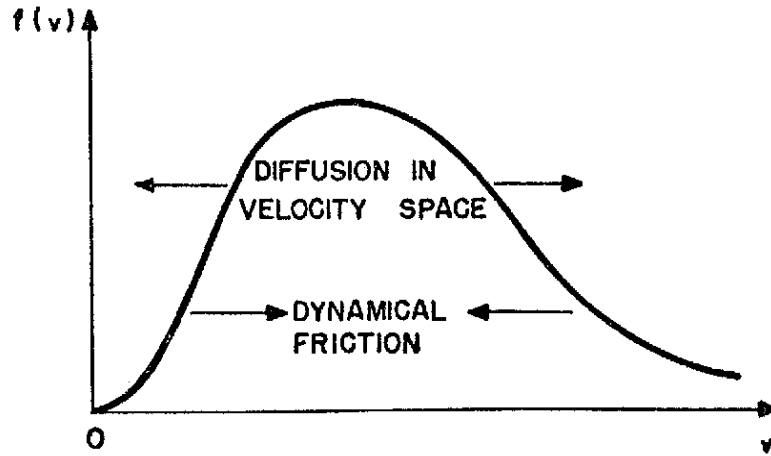

Fig. 5 - Illustrating the processes of dynamical friction and diffusion in velocity space.

5.2 - The Fokker-Planck coefficients for Coulomb interactions

We now evaluate the coefficients of dynamical friction $\langle \Delta v_i \rangle_{av}$ and diffusion in velocity $\langle \Delta v_i \Delta v_j \rangle_{av}$, which appear in the Fokker-Planck collision term (5.15), for the case of the Coulomb interaction. It is convenient to perform first the integral over the solid angle Ω , since it does not require a knowledge of the velocity distribution function $f_{\beta}(\underline{v}_1)$. For this purpose let us write

$$\langle \Delta v_i \rangle_{av} = \int_{v_1} \{ \Delta v_i \} f_{\beta_1} d^3 v_1 \quad (5.16)$$

and

$$\langle \Delta v_i \Delta v_j \rangle_{av} = \int_{v_1} \{ \Delta v_i \Delta v_j \} f_{\beta_1} d^3 v_1 \quad (5.17)$$

where the curly bracket notation has been introduced to represent the following integrals over solid angle

$$\{ \Delta v_i \} = \int_{\Omega} \Delta v_i g \sigma(\Omega) d\Omega \quad (5.18)$$

and

$$\{ \Delta v_i \Delta v_j \} = \int_{\Omega} \Delta v_i \Delta v_j g \sigma(\Omega) d\Omega \quad (5.19)$$

In order to calculate $\{ \Delta v_i \}$ and $\{ \Delta v_i \Delta v_j \}$, we recall first that in the center of mass coordinate system we have, from Eqs. (20.2.5) and (20.2.8),

$$\underline{v} = \underline{c}_0 - \left(\frac{m_\beta}{m_\alpha + m_\beta} \right) \underline{g} \quad (5.20)$$

$$\underline{v}' = \underline{c}_0 - \left(\frac{m_\beta}{m_\alpha + m_\beta} \right) \underline{g}' \quad (5.21)$$

so that

$$\Delta \underline{v} = \underline{v}' - \underline{v} = \left(\frac{m_{\beta}}{m_{\alpha} + m_{\beta}} \right) (\underline{g} - \underline{g}') \quad (5.22)$$

In a Cartesian coordinate system in which the vector \underline{g} is along the z axis (see Fig. 3, of Chapter 20), we have

$$g_z = g \quad ; \quad g_x = g_y = 0 \quad (5.23)$$

and

$$g'_x = g \sin \chi \cos \epsilon \quad (5.24)$$

$$g'_y = g \sin \chi \sin \epsilon \quad (5.25)$$

$$g'_z = g \cos \chi \quad (5.26)$$

In the next sub-section we consider electrons deflected by the field of a stationary group of positive ions, and in this case there is no difference between the center of mass system and the laboratory system. Using Eqs. (5.23) to (5.26), in (5.22), gives

$$\Delta \underline{v} = \left(\frac{m_{\beta}}{m_{\alpha} + m_{\beta}} \right) g \left[(1 - \cos \chi) \hat{z} - \sin \chi (\cos \epsilon \hat{x} + \sin \epsilon \hat{y}) \right] \quad (5.27)$$

The differential scattering cross section for the Coulomb potential was calculated in section 7, of Chapter 20, and is given by

$$\sigma(\chi) = \frac{b_0^2}{4 \sin^4(\chi/2)} = \frac{b_0^2}{(1 - \cos \chi)^2} \quad (5.28)$$

[see Eqs. (20.7.3) and (20.7.4)] where b_0 is defined in Eq. (20.4.9).

Proceeding in the evaluation of $\{\Delta v_i\} = \{v_i' - v_i\}$ for $i = x, y, z$, let us first calculate $\{\Delta v_z\}$. From Eqs. (5.18), (5.27) and (5.28), we have

$$\{\Delta v_z\} = \int_{\Omega} \Delta v_z g \sigma(\Omega) d\Omega = \left(\frac{m_\beta}{m_\alpha + m_\beta} \right) g^2 b_0^2 \int_0^{2\pi} d\epsilon \int_{\chi_{\min}}^{\pi} \frac{\sin \chi}{(1 - \cos \chi)} d\chi \quad (5.29)$$

where the lower limit of the integral in χ was taken to be χ_{\min} , in order to avoid the divergence of the integral that would result if we take $\chi_{\min} = 0$. As we have seen, the charged particles in the plasma that are separated by distances greater than λ_D are effectively shielded from one another. Therefore, in order to avoid an infinite result for the integral in (5.29), we take the lower limit χ_{\min} to be the value of the scattering angle that corresponds to an impact parameter equal to λ_D .

With reference to Eq. (20.4.13) let us introduce the new variable

$$u = \frac{b}{b_0} = \cot \left(\frac{\chi}{2} \right) \quad (5.30)$$

from which we obtain

$$du = - \frac{d\chi}{(1 - \cos \chi)} \quad (5.31)$$

and

$$\sin \chi = \frac{2u}{(1 + u^2)} \quad (5.32)$$

With this change of variables and introducing the cut-off value for the impact parameter at $b_c = \lambda_D$, that is, at

$$u_c = \frac{\lambda_D}{b_0} = \Lambda \quad (5.33)$$

we obtain for Eq. (5.29),

$$\{ \Delta v_z \} = 2\pi \left(\frac{m_\beta}{m_\alpha + m_\beta} \right) g^2 b_0^2 \int_{\Lambda}^0 \frac{2u}{(1 + u^2)} (-du)$$

$$\begin{aligned}
 &= 4\pi \left(\frac{m_\beta}{m_\alpha + m_\beta} \right) g^2 b_0^2 \int_0^\Lambda \frac{u}{(1+u^2)} du \\
 &= 2\pi \left(\frac{m_\beta}{m_\alpha + m_\beta} \right) g^2 b_0^2 \ln(1+\Lambda^2)
 \end{aligned} \tag{5.34}$$

In general $\Lambda \gg 1$, so that $\ln(1+\Lambda^2) \approx 2 \ln \Lambda$ and Eq. (5.34) simplifies to

$$\{\Delta v_z\} = \left(\frac{m_\beta}{m_\alpha + m_\beta} \right) \frac{Z^2 e^4 \ln \Lambda}{4\pi \epsilon_0^2 \mu^2 g^2} \tag{5.35}$$

where we have substituted b_0 by the expression given in (20.4.9).
Introducing the notation

$$\Theta = \frac{Z^2 e^4 \ln \Lambda}{4\pi \epsilon_0^2 \mu^2} \tag{5.36}$$

we can write (5.35) as

$$\{\Delta v_z\} = \left(\frac{m_\beta}{m_\alpha + m_\beta} \right) \frac{\Theta}{g^2} \tag{5.37}$$

Next let us consider the quantities $\{\Delta v_x\}$ and $\{\Delta v_y\}$.
From Eqs. (5.18) and (5.27) we see that these quantities involve

integrals of either $\cos \epsilon$ or $\sin \epsilon$ from 0 to 2π , which are clearly equal to zero. Therefore,

$$\{\Delta v_x\} = \{\Delta v_y\} = 0 \quad (5.38)$$

In a similar way, it can be shown from Eqs. (5.19) and (5.27) that

$$\{\Delta v_i \Delta v_j\} = 0 \quad \text{for } i \neq j \quad (5.39)$$

since the integrals over ϵ from 0 to 2π vanish.

To evaluate $\{\Delta v_z \Delta v_z\} = \{\Delta v_z^2\}$ we use Eqs. (5.19), (5.27) and (5.28), which give

$$\{\Delta v_z^2\} = 2\pi \left(\frac{m_\beta}{m_\alpha + m_\beta} \right)^2 g^3 b_0^2 \int_{\chi_{\min}}^{\pi} \sin \chi \, d\chi \quad (5.40)$$

Changing variables according to (5.30), we obtain

$$\begin{aligned} \{\Delta v_z^2\} &= 2\pi \left(\frac{m_\beta}{m_\alpha + m_\beta} \right)^2 g^3 b_0^2 \int_{\Lambda}^0 \frac{4u}{(1+u^2)^2} (-du) \\ &= 4\pi \left(\frac{m_\beta}{m_\alpha + m_\beta} \right)^2 g^3 b_0^2 \frac{\Lambda^2}{(1+\Lambda^2)} \end{aligned} \quad (5.41)$$

Since $\Lambda \gg 1$, (5.41) simplifies to

$$\{\Delta v_z^2\} = 4\pi \left(\frac{m_\beta}{m_\alpha + m_\beta} \right)^2 g^3 b_0^2 = \left(\frac{m_\beta}{m_\alpha + m_\beta} \right)^2 \frac{Z^2 e^4}{4\pi \epsilon_0^2 \mu^2 g} \quad (5.42)$$

or, using the notation introduced in (5.36),

$$\{\Delta v_z^2\} = \left(\frac{m_\beta}{m_\alpha + m_\beta} \right)^2 \frac{\Theta}{g \ln \Lambda} \quad (5.43)$$

In a similar way, we can calculate $\{\Delta v_x^2\}$ and $\{\Delta v_y^2\}$ from Eqs. (5.19), (5.27) and (5.28), which give

$$\{\Delta v_x^2\} = \left(\frac{m_\beta}{m_\alpha + m_\beta} \right)^2 g^3 b_0^2 \int_0^{2\pi} \cos^2 \epsilon \, d\epsilon \int_{\chi_{\min}}^{\pi} \frac{\sin^3 \chi}{(1 - \cos \chi)^2} d\chi \quad (5.44)$$

$$\{\Delta v_y^2\} = \left(\frac{m_\beta}{m_\alpha + m_\beta} \right)^2 g^3 b_0^2 \int_0^{2\pi} \sin^2 \epsilon \, d\epsilon \int_{\chi_{\min}}^{\pi} \frac{\sin^3 \chi}{(1 - \cos \chi)^2} d\chi \quad (5.45)$$

Therefore, evaluating the integral over ϵ we find

$$\{\Delta v_x^2\} = \{\Delta v_y^2\} = \pi \left(\frac{m_\beta}{m_\alpha + m_\beta} \right)^2 g^3 b_0^2 \int_{\chi_{\min}}^{\pi} \frac{\sin^3 \chi}{(1 - \cos \chi)^2} d\chi \quad (5.46)$$

If we change variables according to Eq. (5.30), we readily find that (5.46) can be written as

$$\begin{aligned} \{\Delta v_x^2\} = \{\Delta v_y^2\} &= 4\pi \left(\frac{m_\beta}{m_\alpha + m_\beta} \right)^2 g^3 b_0^2 \int_0^\Lambda \frac{u^3}{(1+u^2)^2} du \\ &= 2\pi \left(\frac{m_\beta}{m_\alpha + m_\beta} \right)^2 g^3 b_0^2 \left[\ln(1+\Lambda^2) - \frac{\Lambda^2}{(1+\Lambda^2)} \right] \end{aligned} \quad (5.47)$$

Since $\Lambda \gg 1$, and replacing b_0 by (20.4.9), we can write

$$\begin{aligned} \{\Delta v_x^2\} = \{\Delta v_y^2\} &= \left(\frac{m_\beta}{m_\alpha + m_\beta} \right)^2 \frac{Z^2 e^4 \ln \Lambda}{4\pi \epsilon_0^2 \mu^2 g} \\ &= \left(\frac{m_\beta}{m_\alpha + m_\beta} \right)^2 \frac{\Theta}{g} \end{aligned} \quad (5.48)$$

The next step in the evaluation of the Fokker-Planck coefficients consists in integrating the values of $\{\Delta v_i\}$ and $\{\Delta v_i \Delta v_j\}$, for $i, j = x, y, z$, over the distribution function of the particles which constitute the scattering centers. Thus, using the results we have just calculated we find

$$\langle \Delta v_z \rangle_{av} = \left(\frac{m_\beta}{m_\alpha + m_\beta} \right) \int_{v_1} \frac{\Theta}{g^2} f_{\beta_1} d^3v_1 \quad (5.49)$$

$$\langle \Delta v_z^2 \rangle_{av} = \left(\frac{m_\beta}{m_\alpha + m_\beta} \right)^2 \int_{v_1} \frac{\Theta}{g \ln \Lambda} f_{\beta_1} d^3v_1 \quad (5.50)$$

$$\langle \Delta v_x^2 \rangle_{av} = \langle \Delta v_y^2 \rangle_{av} = \left(\frac{m_\beta}{m_\alpha + m_\beta} \right)^2 \int_{v_1} \frac{\Theta}{g} f_{\beta_1} d^3v_1 \quad (5.51)$$

All other coefficients vanish.

5.3 - Application to electron-ion collisions

Let us calculate the Fokker-Planck coefficients for the case of electron-ion collisions. For simplicity we assume that the electron is colliding with a field of heavy *stationary* positive ions. This assumption is reasonable, since on the average the electron velocities are much larger than the ion velocities ($\langle v_i^2 \rangle = 3kT_i/m_i$ while $\langle v_e^2 \rangle = 3kT_e/m_e$ and generally $T_e/m_e \gg T_i/m_i$). Thus, assuming that the positive ions are motionless we can set their velocity distribution function equal to the Dirac delta function,

$$f_{\beta_1} = n_0 \delta(v_{1x}) \delta(v_{1y}) \delta(v_{1z}) \quad (5.52)$$

In addition, because $m_i \gg m_e$, we can take $(m_e + m_i) \approx m_i$ and $\mu \approx m_e$.

Substituting (5.52) into Eqs. (5.49) through (5.51), we obtain at once

$$\langle \Delta v_z \rangle_{av} \equiv \langle \Delta v_{\parallel} \rangle_{av} = \frac{n_0 \Theta}{g^2} \quad (5.53)$$

$$\langle \Delta v_z^2 \rangle_{av} \equiv \langle \Delta v_{\parallel}^2 \rangle_{av} = \frac{n_0 \Theta}{g \ln \Lambda} \quad (5.54)$$

$$\langle \Delta v_x^2 \rangle_{av} = \langle \Delta v_y^2 \rangle_{av} \equiv \langle \Delta v_{\perp}^2 \rangle_{av} = \frac{n_0 \Theta}{g} \quad (5.55)$$

where, according to (5.36),

$$\Theta = \frac{Z^2 e^4 \ln \Lambda}{4\pi \epsilon_0^2 m_e^2} \quad (5.56)$$

Since Δv_z is in the direction of the initial relative velocities, we have used in Eqs. (5.53) and (5.54) the notation $\Delta v_z \equiv \Delta v_{\parallel}$, whereas in Eq. (5.55) we have used $\Delta v_x = \Delta v_y = \Delta v_{\perp}$, to denote the change in velocity in the directions parallel and perpendicular to the initial relative velocities, respectively.

PROBLEMS

21.1 - Consider a system consisting of a mixture of *two types* of particles having masses m and M , and subjected to an external force \underline{F} . Denote the corresponding distribution functions by f and g , respectively, and write down the set of coupled Boltzmann transport equations for the system.

21.2 - Consider a plasma in which the electrons and ions are characterized, respectively, by the following distribution functions:

$$f_e = n_0 \left(\frac{m_e}{2\pi k T_e} \right)^{3/2} \exp \left[- \frac{m_e (\underline{v} - \underline{u}_e)^2}{2k T_e} \right]$$

$$f_i = n_0 \left(\frac{m_i}{2\pi k T_i} \right)^{3/2} \exp \left[- \frac{m_i (\underline{v} - \underline{u}_i)^2}{2k T_i} \right]$$

(a) Calculate the difference $(f'_e f'_{i1} - f_e f_{i1})$.

(b) Show that this plasma of electrons and ions are in the equilibrium state, that is, the difference $(f'_e f'_{i1} - f_e f_{i1})$ vanishes, if and only if $\underline{u}_e = \underline{u}_i$ and $T_e = T_i$.

21.3 - Use a Lagrange multiplier technique to show that for a system characterized by the following modified Maxwell-Boltzmann distribution,

$$f(\underline{r}, \underline{v}) = n(\underline{r}) \left(\frac{m}{2\pi kT} \right)^{3/2} \exp \left(- \frac{m\underline{v}^2}{2kT} \right)$$

where T is constant, the entropy S defined by

$$S = -k \int_{\underline{r}} \int_{\underline{v}} f \ln f \, d^3v \, d^3r$$

is a maximum when the density n is a constant, independent of \underline{r} . Consider that the system has a total of N particles in a fixed volume V at a temperature T .

21.4 - Consider the case of *Maxwell molecules*, for which the interparticle force is of the form

$$F(r) = \frac{K}{r^5}$$

where K is a constant.

(a) Without specifying the form of the distribution functions $f_{\alpha}(\underline{v})$ and $f_{\beta_1}(\underline{v}_1)$ for the particles of type α and β , show that the time rate of change of momentum for the particles of

type α per unit volume, due to collisions, is given by

$$\left(\frac{\delta \vec{P}_\alpha}{\delta t}\right)_{\text{coll}} \equiv \int_{\vec{v}} m_\alpha \vec{c}_\alpha \left(\frac{\delta f_\alpha}{\delta t}\right)_{\text{coll}} d^3v = \sum_{\beta} n_\alpha m_\alpha v_{\alpha\beta} (\vec{u}_\beta - \vec{u}_\alpha)$$

where $v_{\alpha\beta}$ is the collision frequency for momentum transfer given explicitly by

$$v_{\alpha\beta} = 2\pi (K\mu)^{1/2} \frac{n_\beta}{m_\alpha} A_1(5)$$

where $A_1(5)$ is a dimensionless number (of order unity) defined by (with $p = 5$ and $\ell = 1$)

$$A_\ell(p) = \int_0^\infty (1 - \cos^\ell \chi) v_0 dv_0$$

with

$$v_0 = b \left(\frac{\mu g^2}{K}\right)^{1/(p-1)}$$

Also,

$$n_\alpha = \int_{\vec{v}} f_\alpha d^3v ; \quad \vec{u}_\alpha = \frac{1}{n_\alpha} \int_{\vec{v}} \vec{v} f_\alpha d^3v$$

$$n_\beta = \int_{\vec{v}_1} f_{\beta 1} d^3v_1 ; \quad \vec{u}_\beta = \frac{1}{n_\beta} \int_{\vec{v}_1} \vec{v}_1 f_{\beta 1} d^3v_1$$

and $(\delta f_\alpha / \delta t)_{\text{coll}}$ denotes the Boltzmann collision term.

(b) For the same case, show that the time rate of change of the energy for the particles of type α per unit volume, due to collisions, is given by

$$\left(\frac{\delta E_\alpha}{\delta t}\right)_{\text{coll}} \equiv \int_V \frac{1}{2} m_\alpha c_\alpha^2 \left(\frac{\delta f_\alpha}{\delta t}\right) d^3v = \sum_\beta \frac{n_\alpha m_\alpha v_{\alpha\beta}}{(m_\alpha + m_\beta)} \cdot$$

$$\cdot [3k (T_\beta - T_\alpha) + m_\beta (\underline{u}_\beta - \underline{u}_\alpha)^2]$$

where

$$T_\alpha = \frac{m_\alpha}{3k} \langle c_\alpha^2 \rangle = \frac{m_\alpha}{3k} \frac{1}{n_\alpha} \int_V c_\alpha^2 f_\alpha d^3v$$

$$T_\beta = \frac{m_\beta}{3k} \langle c_{\beta 1}^2 \rangle = \frac{m_\beta}{3k} \frac{1}{n_\beta} \int_{V_1} c_{\beta 1}^2 f_{\beta 1} d^3v_1$$

21.5 - Consider a gas mixture of two types of particles ($\alpha = 1, 2$), each one characterized by a Maxwellian distribution function

$$f_\alpha(\underline{v}_\alpha) = n_\alpha \left(\frac{m_\alpha}{2\pi k T_\alpha}\right)^{3/2} \exp\left(-\frac{m_\alpha v_\alpha^2}{2k T_\alpha}\right); (\alpha = 1, 2)$$

with its own mass, density and temperature.

(a) Make the following transformation of velocity variables

$$\underline{v}_1 = \underline{\bar{v}}_c + \bar{M}_2 \underline{g}$$

$$\underline{v}_2 = \underline{\bar{v}}_c - \bar{M}_1 \underline{g}$$

where $\underline{\bar{v}}_c$ is a velocity similar to the center of mass velocity, \underline{g} is the relative velocity between the two species

$$(\underline{g} = \underline{v}_1 - \underline{v}_2) \text{ and}$$

$$\bar{M}_1 = (m_1/T_1) / [(m_1/T_1) + (m_2/T_2)]$$

$$\bar{M}_2 = (m_2/T_2) / [(m_1/T_1) + (m_2/T_2)]$$

Show that the Jacobian of this transformation satisfies

$$| J | = \left| \frac{\partial(\underline{v}_c, \underline{g})}{\partial(\underline{v}_1, \underline{v}_2)} \right| = 1$$

$$\text{so that } d^3v_c d^3g = d^3v_1 d^3v_2.$$

(b) The relative speed between the two species, $g = | \underline{v}_1 - \underline{v}_2 |$, when averaged over both their velocity distribution functions, is given by

$$\langle g \rangle = \frac{1}{n_1 n_2} \int \int_{v_1 v_2} g f_1(\underline{v}_1) f_2(\underline{v}_2) d^3v_1 d^3v_2$$

Transform the variables of integration \underline{v}_1 and \underline{v}_2 to \underline{v}_c and \underline{g} , and perform the integrals over \underline{v}_c and \underline{g} , to show that

$$\langle g \rangle = \left[\left(\frac{8k}{\pi} \right) \left(\frac{T_1}{m_1} + \frac{T_2}{m_2} \right) \right]^{1/2}$$

(c) If only one kind of particles is present, so that $m_1 = m_2 = m$, $T_1 = T_2 = T$, and $n_1 = n_2 = n$, show that

$$\langle g \rangle = \sqrt{2} \langle v \rangle = \left(\frac{8kT}{\pi\mu} \right)^{1/2}$$

where $\langle v \rangle = (8kT/\pi m)^{1/2}$ is the average speed and $\mu = m/2$ is the reduced mass. If the mutual scattering cross section is σ , show that the collision frequency in a homogeneous Maxwellian gas is given by

$$\nu = n \sigma \langle g \rangle = 4 n \sigma \left(\frac{kT}{\pi m} \right)^{1/2}$$

21.6 - Consider the following expressions which define the Fokker-Planck coefficients of dynamical friction and of diffusion in velocity,

$$\langle \Delta v_i \rangle_{av} = \int_{\Omega} \int_{\underline{v}_1} \Delta v_i g \sigma(\Omega) d\Omega f_{\beta 1} d^3v_1$$

$$\langle \Delta v_i \Delta v_j \rangle_{av} = \int \int_{\Omega} \Delta v_i \Delta v_j g \sigma(\Omega) d\Omega f_{\beta 1} d^3 v_1$$

(a) With reference to Fig. P.21.1, verify that

$$\Delta v_x = - \frac{m_\beta}{m_\alpha + m_\beta} g \sin \chi \cos \epsilon$$

$$\Delta v_y = - \frac{m_\beta}{m_\alpha + m_\beta} g \sin \chi \sin \epsilon$$

$$\Delta v_z = \frac{m_\beta}{m_\alpha + m_\beta} g (1 - \cos \chi)$$

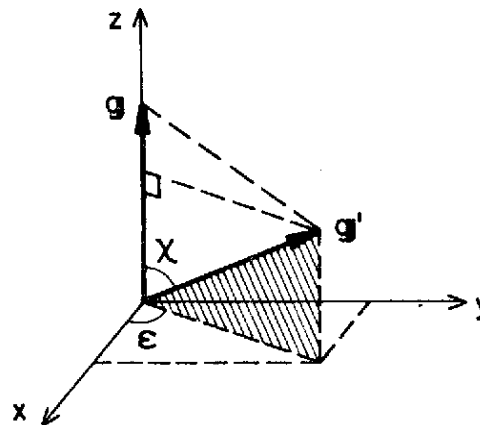

Fig. P.21.1

For a general inverse-power interparticle force of the form $F(r) = K/r^p$, where K is a constant and p is a positive integer number, show that [see Eq. (5.18)]

$$\{\Delta v_x\} = \{\Delta v_y\} = 0$$

$$\{\Delta v_z\} = \mu g^2 \sigma_m / m_\alpha$$

where $\mu = m_\alpha m_\beta / (m_\alpha + m_\beta)$ is the reduced mass and σ_m is the momentum transfer cross section given by

$$\sigma_m = 2\pi \left(\frac{K}{\mu g^2} \right)^{2/(p-1)} A_1(p)$$

where

$$A_\ell(p) = \int_0^\infty (1 - \cos^\ell x) v_0 dv_0$$

$$v_0 = b \left(\frac{\mu g^2}{K} \right)^{1/(p-1)}$$

Verify also that [see Eq. (5.19)]

$$\{\Delta v_i \Delta v_j\} = 0 \quad \text{for } i \neq j$$

$$\{\Delta v_x^2\} = \{\Delta v_y^2\} = \pi \frac{\mu^2 g^3}{m_\alpha^2} \left(\frac{K}{\mu g^2} \right)^{2/(p-1)} A_2(p)$$

$$\{\Delta v_z^2\} = 2\pi \frac{\mu^2 g^3}{m_\alpha^2} \left(\frac{K}{\mu g^2} \right)^{2/(p-1)} [2 A_1(p) - A_2(p)]$$

(b) For the case of *Maxwell molecules* ($p = 5$), where the results are independent of $f_{\beta 1}$, show that the Fokker-Planck coefficients are given by

$$\langle \Delta v_x \rangle_{av} = \langle \Delta v_y \rangle_{av} = 0$$

$$\langle \Delta v_z \rangle_{av} = v_{\alpha\beta} \langle g \rangle_{\beta}$$

$$\langle \Delta v_i \Delta v_j \rangle_{av} = 0 \text{ for } i \neq j$$

$$\langle \Delta v_x^2 \rangle_{av} = \langle \Delta v_y^2 \rangle_{av} = \frac{\mu}{m_{\alpha}} \frac{A_2(5)}{2A_1(5)} v_{\alpha\beta} \langle g^2 \rangle_{\beta}$$

$$\langle \Delta v_z^2 \rangle_{av} = \frac{\mu}{m_{\alpha}} \left[2 - \frac{A_2(5)}{A_1(5)} \right] v_{\alpha\beta} \langle g^2 \rangle_{\beta}$$

where

$$v_{\alpha\beta} = 2\pi (K\mu)^{1/2} \frac{n_{\beta}}{m_{\alpha}} A_1(5)$$

$$\langle g^i \rangle_{\beta} = \frac{1}{n_{\beta}} \int_{v_1} g^i f_{\beta 1} d^3v_1 ; (i = 1, 2)$$

(c) Calculate the Fokker-Planck coefficients for the case of *Coulomb interactions* ($p = 2$) using the results of part (a) and of Problem 20.6, in terms of integrals over $f_{\beta 1}$, and compare with the results derived in sub-section 5.2.

(d) Calculate the Fokker-Planck coefficients for electron-electron interactions, when $f_{\beta 1}$ is the Maxwellian distribution function. Refer to Eqs. (5.49), (5.50), and (5.51).